

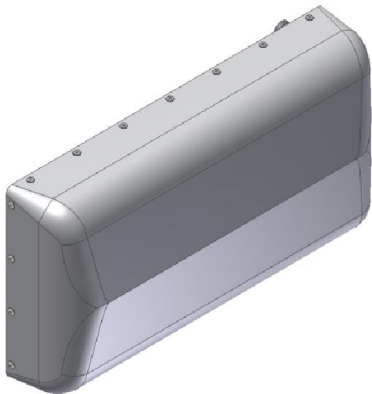

XEA-FRO-130

X-Pol, 698-945 MHz, 1710-2170MHz, 12", 30° Azimuth



- Most widely used stadium antenna
- Large box indoor coverage
- Includes flexible stadium bracket
- Broadband radiators
- Suitable for LTE/CDMA/UMTS/GSM

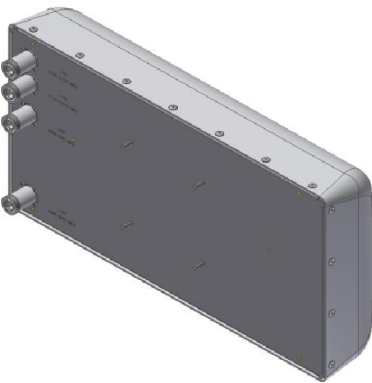

Available with Intergrated Diplexers

Reduces mainline cables
Eliminates external tower devices

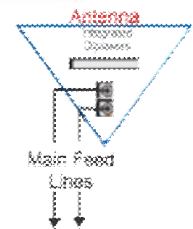

Electrical Specifications

Frequency Band, MHz	698-824	824-945	1710-1880	1850-1910	1900-2170
Horizontal Beamwidth, 3dB points	32°	27°	30°	28°	27°
Gain, dBi	11.0	11.6	11.3	11.4	11.6
Vertical Beamwidth, 3dB points	72°	65°	68°	66°	65°
Front-to-Back at 180°, dB	21	25	21	21	21
Polarization	+/-45°		+/-45°		
Electrical Downtilt	0°		0°		
VSWR/Return Loss, dB, Maximum	1.7:1/-11.7		1.7:1/11.7		
Isolation Between Ports, dB, Mimimum	-25		-25		
Intermodulation (2x20w), IM3, dBc, Max	-150		-150		
Impedance, ohms	50		50		
Maximum Power Per Connector, CW	250 @ 800 MHz		125 @ 1990 MHz		
Lightning Protection	DC Ground		DC Ground		

www.cssantenna.com

410-612-0080

customerservice@cssantenna.com



XEA-FRO-130

X-Pol, 698-945 MHz, 1710-2170MHz, 12", 30° Azimuth

Mechanical Specifications

Dimensions, Length/Width/Depth	12.0/24.3/5.6 in (304.8/617.2/142.2 mm)
Connector (Quantity) Type	(2 or 4) 7-16 DIN Female or Type N
Connector Torque	220-265 lbf-in (23-30 N-m)
Connector Location	Back
Antenna Weight	13.2 lb (6.0 kg)
Bracket Weight	5.0 lb (2.3 kg)
Standard Bracket Kit	CSS P/N 919050
Mechanical Downtilt Range	+/- 35° Lateral & +/- 55° Vertical
Radome Material	High Strength Luran, UV Stabilized, ASTM D1925
Wind Survival	120 mph (193 km/h)
Front Wind Load	51.3 lbf (228.2 N) @100mph
Equivalent Flat Plate	1.2 sq-ft (c=2) @ 100mph

Order Information

Model	Description
XEA-FRO-130-00	X-Pol dual band, 0° electrical downtilt with four DIN connectors
XEA-FRO-130-00-IP	X-Pol dual band, 0° electrical downtilt with two DIN connectors and integrated diplexers.
XEA-FRO-130-00-N	X-Pol dual band, 0° electrical downtilt with four N connectors.
XEA-FRO-130-00-IP-N	X-Pol dual band, 0° electrical downtilt with two N connectors and integrated diplexers



XEA-FRO-130

X-Pol, 698-945 MHz, 1710-2170MHz, 12", 30° Azimuth

Patterns Measured @ 750 MHz

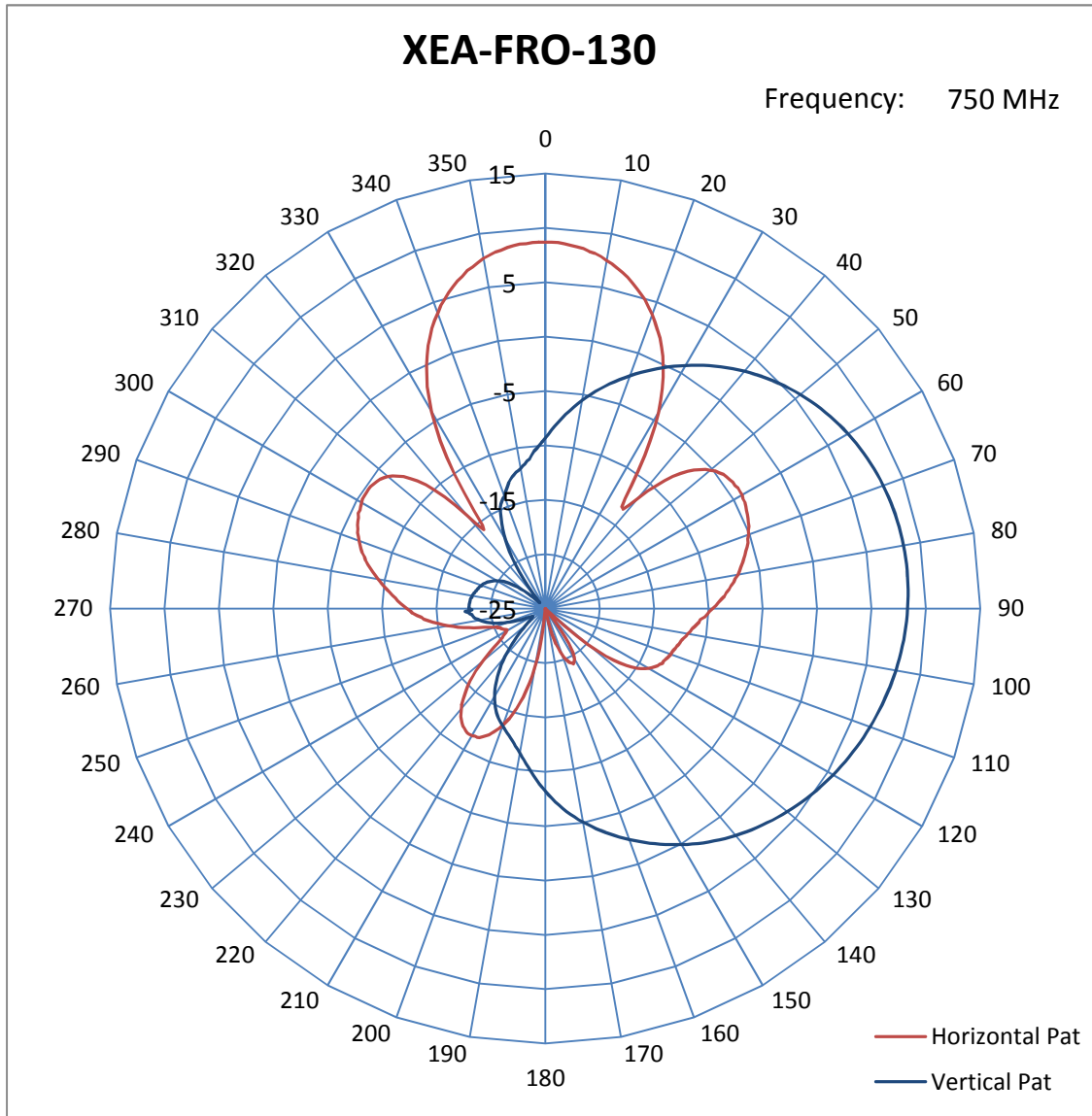

Center = -25dB, with 5 dB/radial division and 10° angular division

www.cssantenna.com

410-612-0080

customerservice@cssantenna.com



XEA-FRO-130

X-Pol, 698-945 MHz, 1710-2170MHz, 12", 30° Azimuth

Patterns Measured @ 850MHz

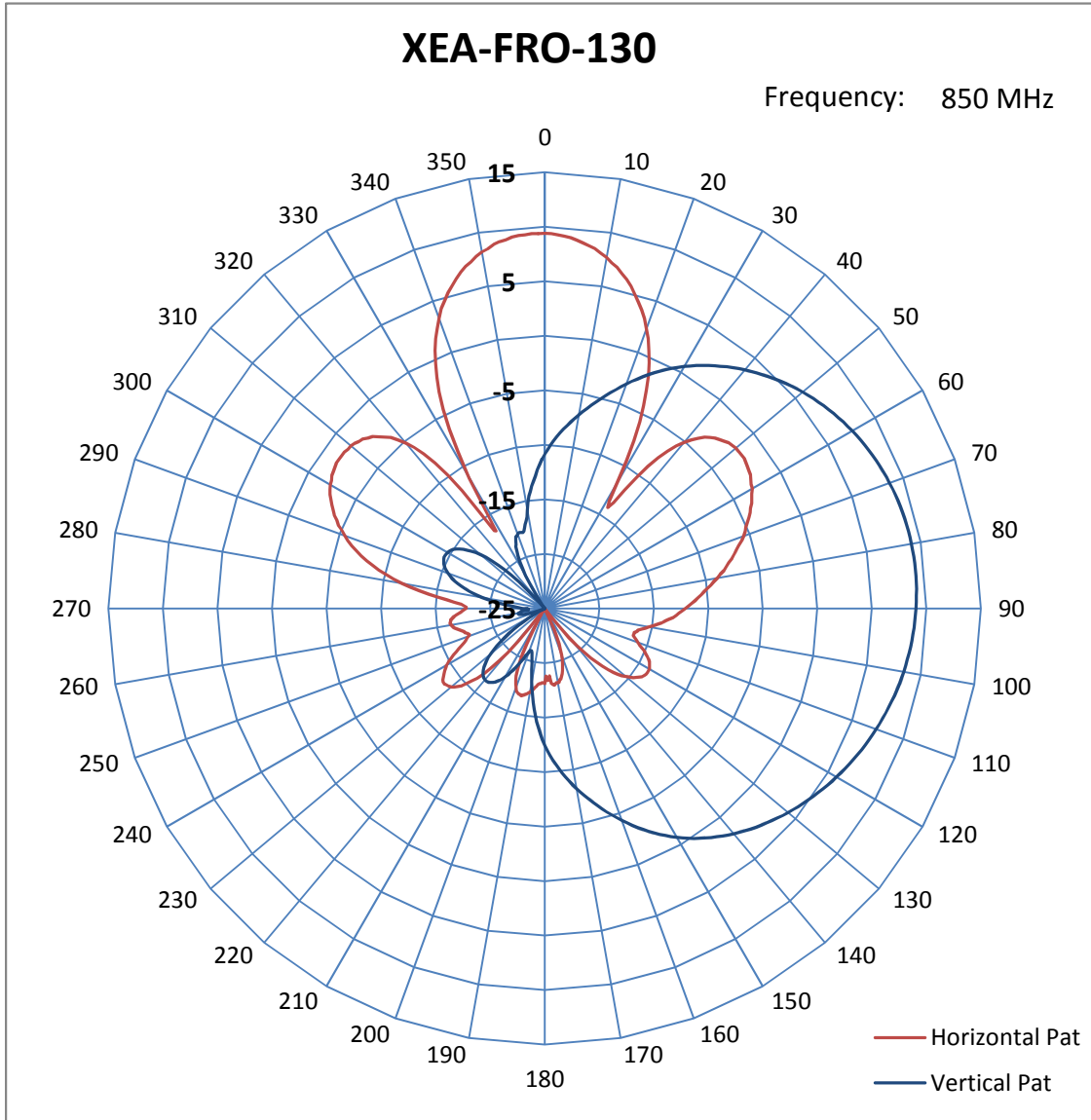

Center = -25dB, with 5 dB/radial division and 10° angular division



XEA-FRO-130

X-Pol, 698-945 MHz, 1710-2170MHz, 12", 30° Azimuth

Patterns Measured @ 1780MHz

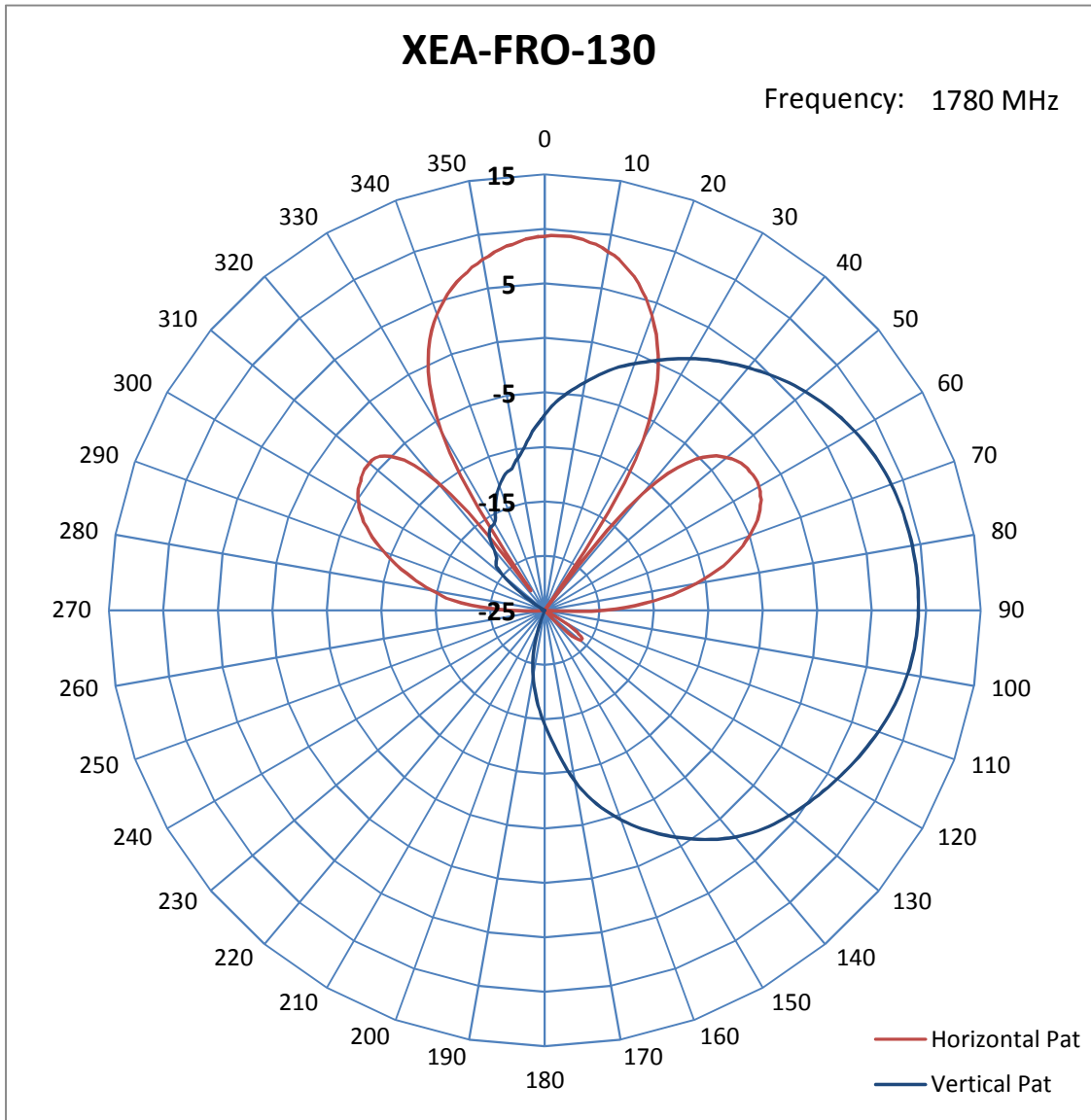

Center = -25dB, with 5 dB/radial division and 10° angular division

www.cssantenna.com

410-612-0080

customerservice@cssantenna.com



XEA-FRO-130

X-Pol, 698-945 MHz, 1710-2170MHz, 12", 30° Azimuth

Patterns Measured @ 1920MHz

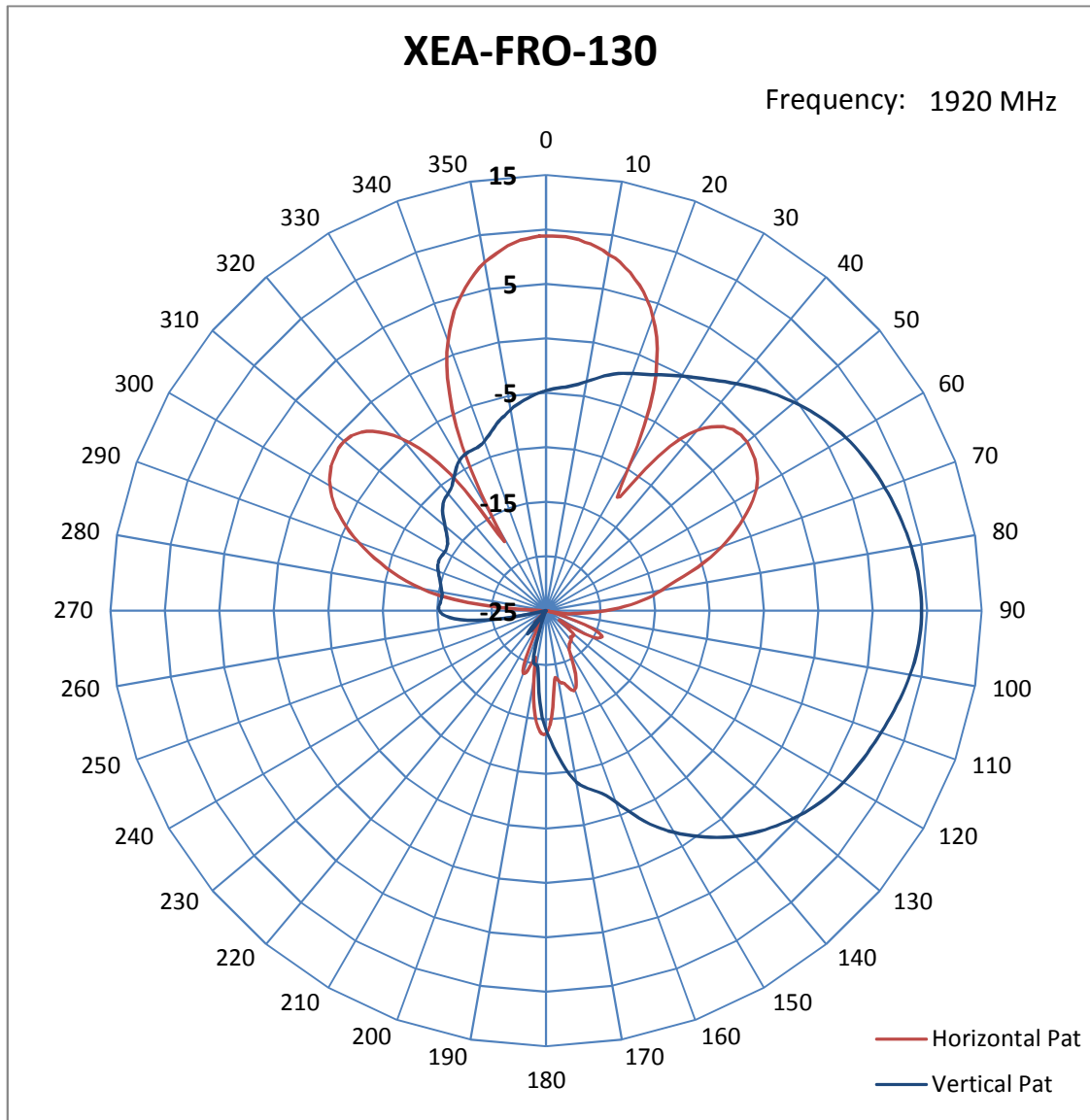

Center = -25dB, with 5 dB/radial division and 10° angular division

www.cssantenna.com

410-612-0080

customerservice@cssantenna.com



XEA-FRO-130

X-Pol, 698-945 MHz, 1710-2170MHz, 12", 30° Azimuth

Patterns Measured @ 2120MHz

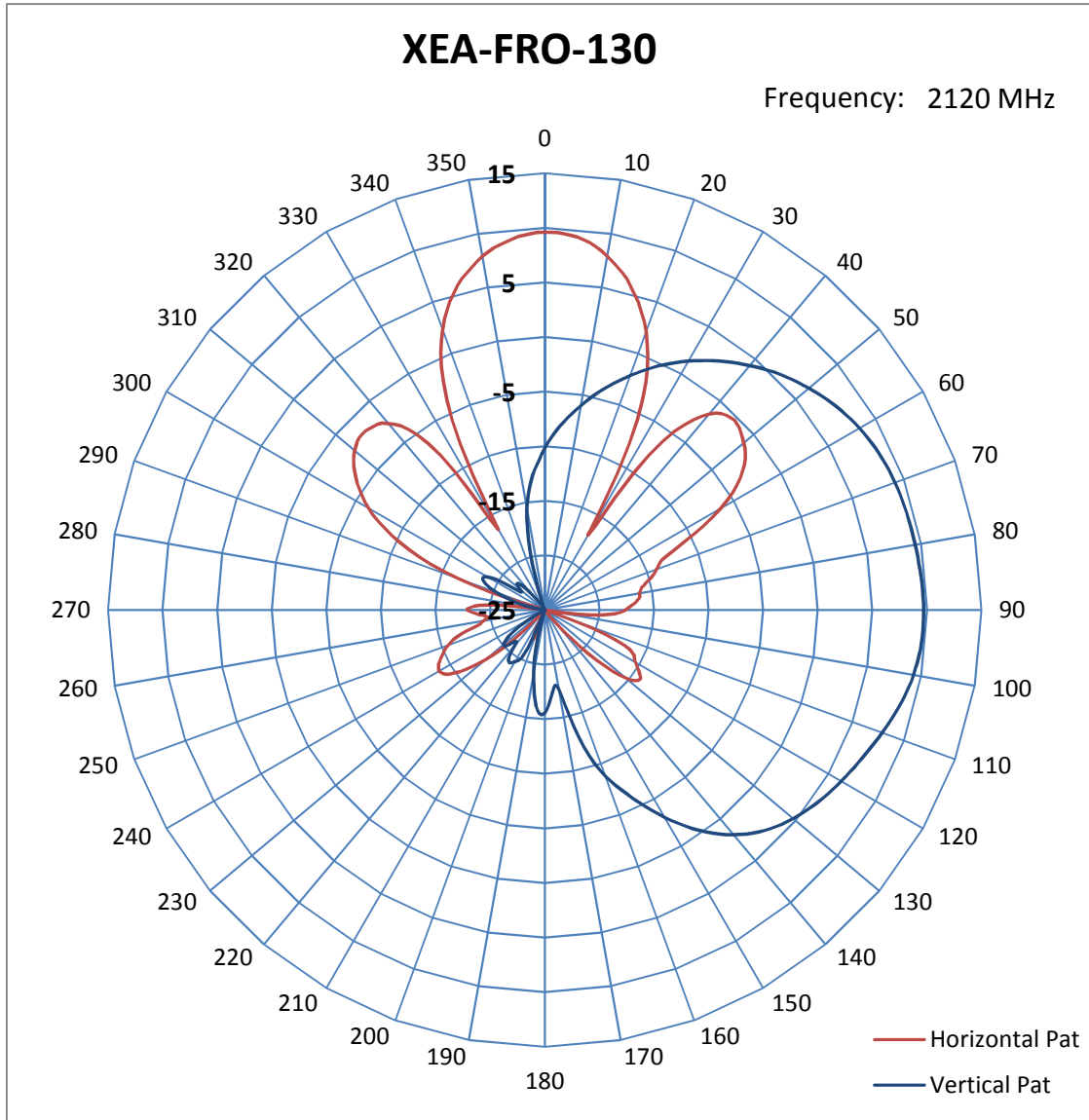

Center = -25dB, with 5 dB/radial division and 10° angular division

www.cssantenna.com

410-612-0080

customerservice@cssantenna.com



XEA-FRO-130

X-Pol, 698-945 MHz, 1710-2170MHz, 12", 30° Azimuth

Mechanical Outline Drawing

XEA-FRO-130

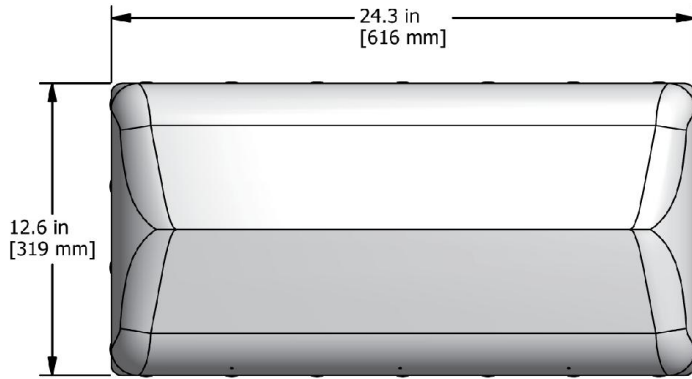

FRONT VIEW

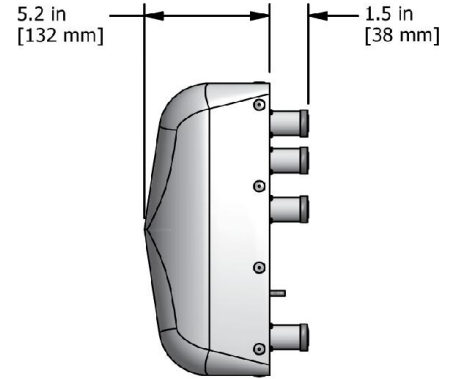

SIDE VIEW

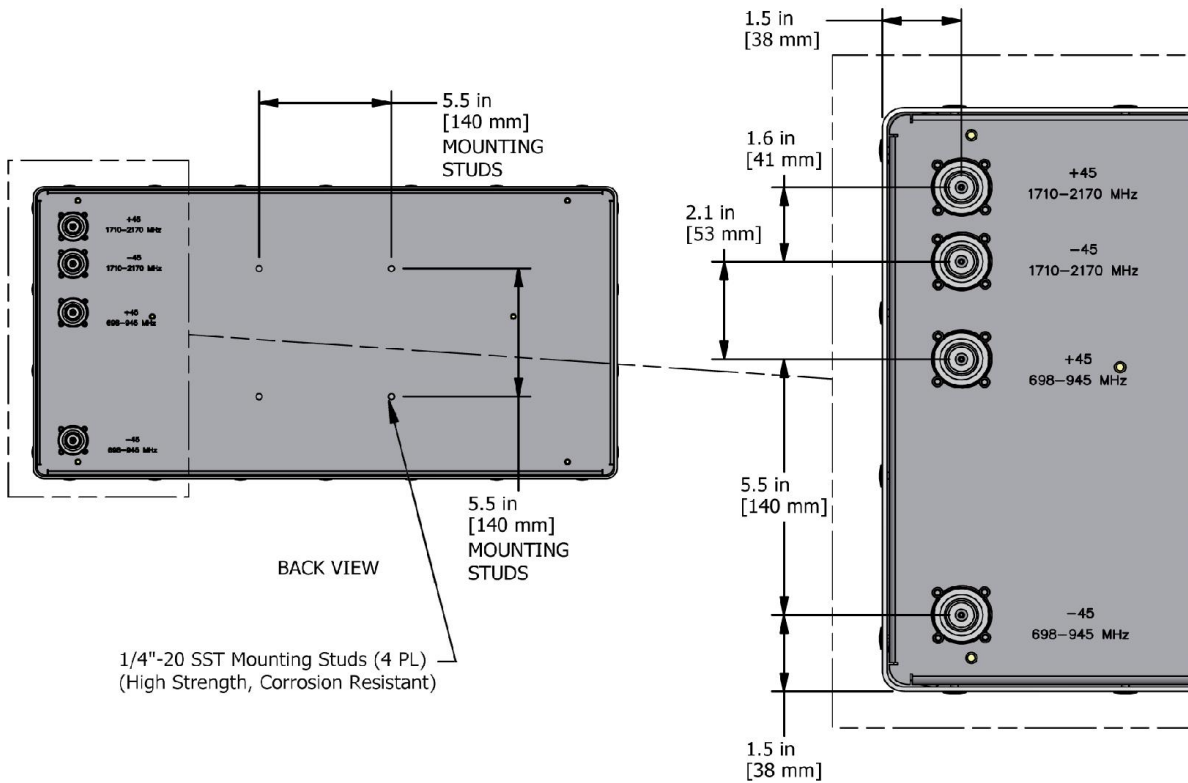



XEA-FRO-130

X-Pol, 698-945 MHz, 1710-2170MHz, 12", 30° Azimuth

Mechanical Outline Drawing

XEA-FRO-130-IP

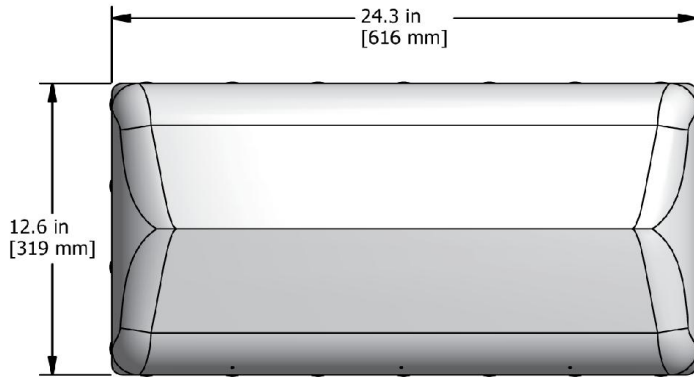

FRONT VIEW

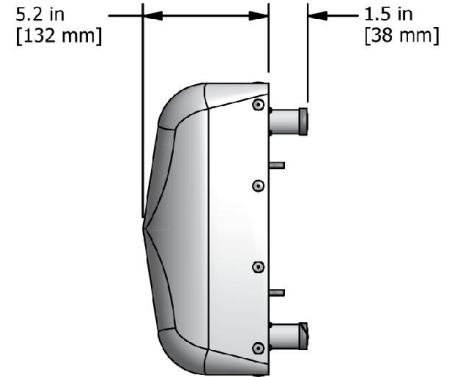

SIDE VIEW

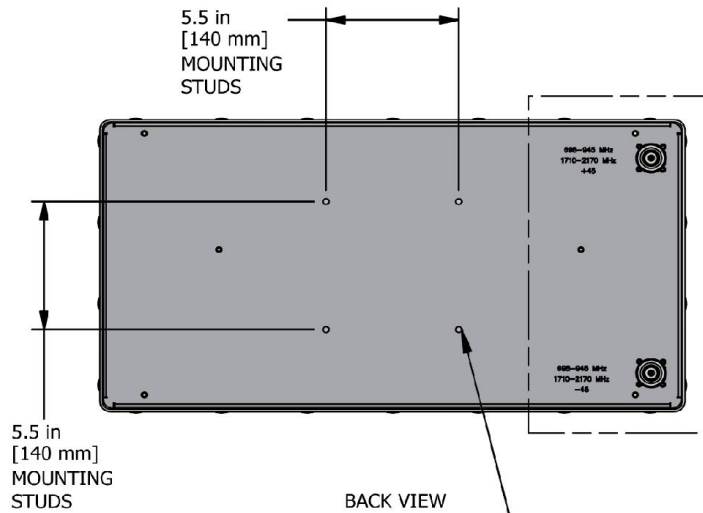

BACK VIEW

1/4"-20 SST Mounting Studs (4 PL)
(High Strength, Corrosion Resistant)

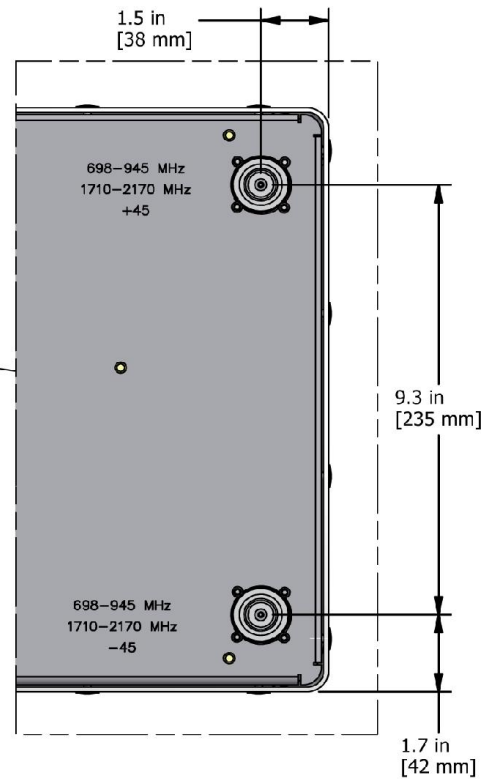



XEA-FRO-130

X-Pol, 698-945 MHz, 1710-2170MHz, 12", 30° Azimuth

Mechanical Outline Drawing

XEA-FRO-130-N

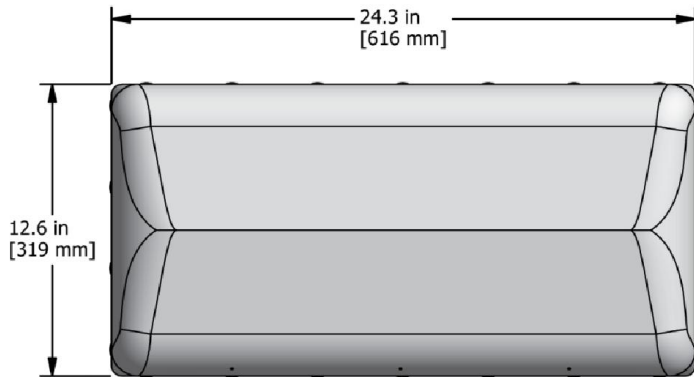

FRONT VIEW

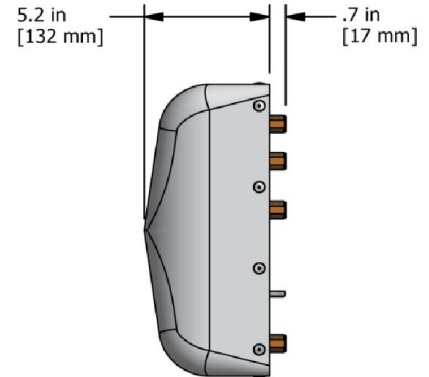

SIDE VIEW

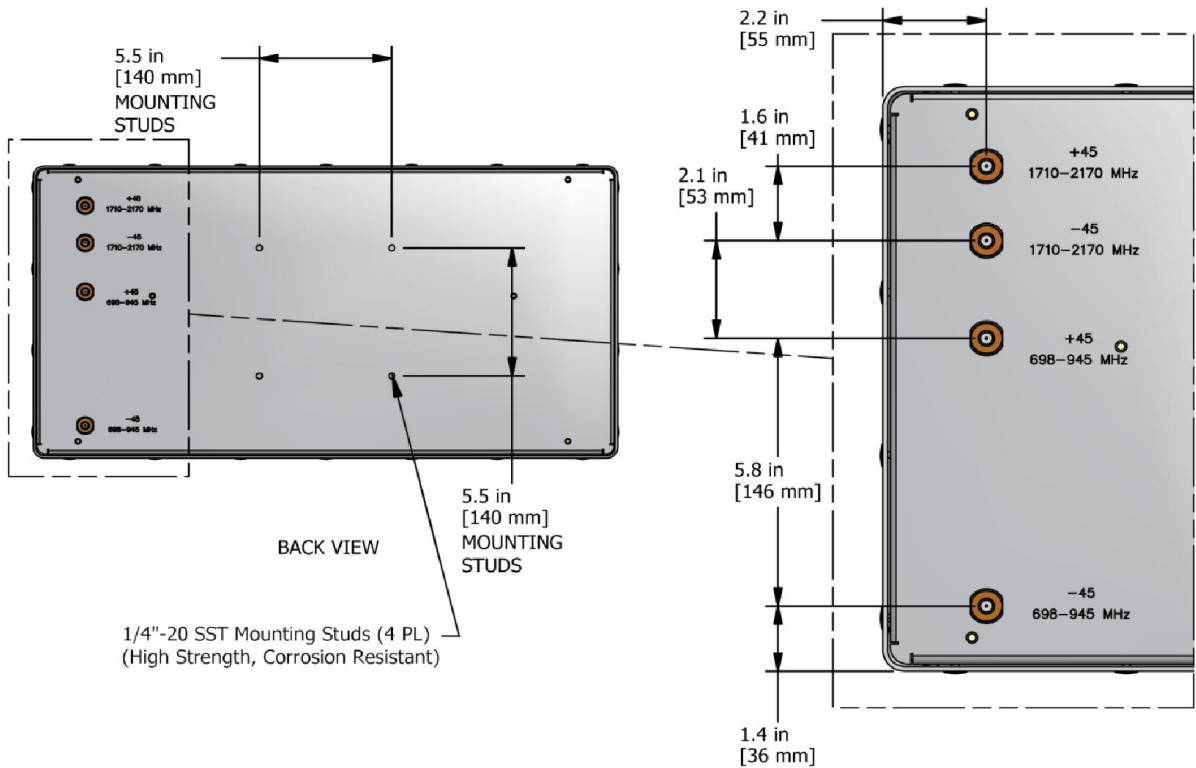

BACK VIEW



XEA-FRO-130

X-Pol, 698-945 MHz, 1710-2170MHz, 12", 30° Azimuth

Mechanical Outline Drawing

XEA-FRO-130-IP-N

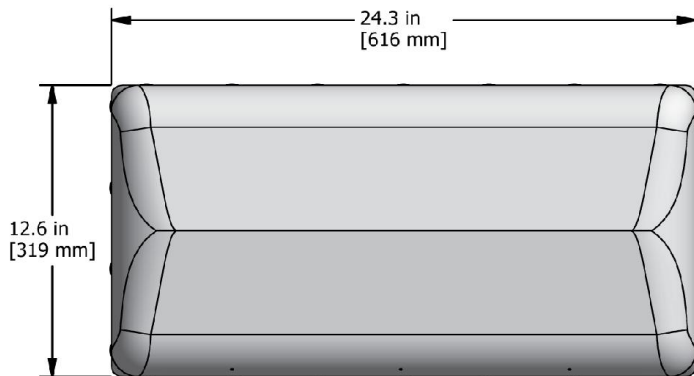

FRONT VIEW

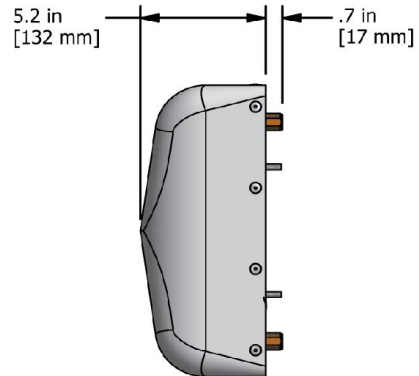

SIDE VIEW

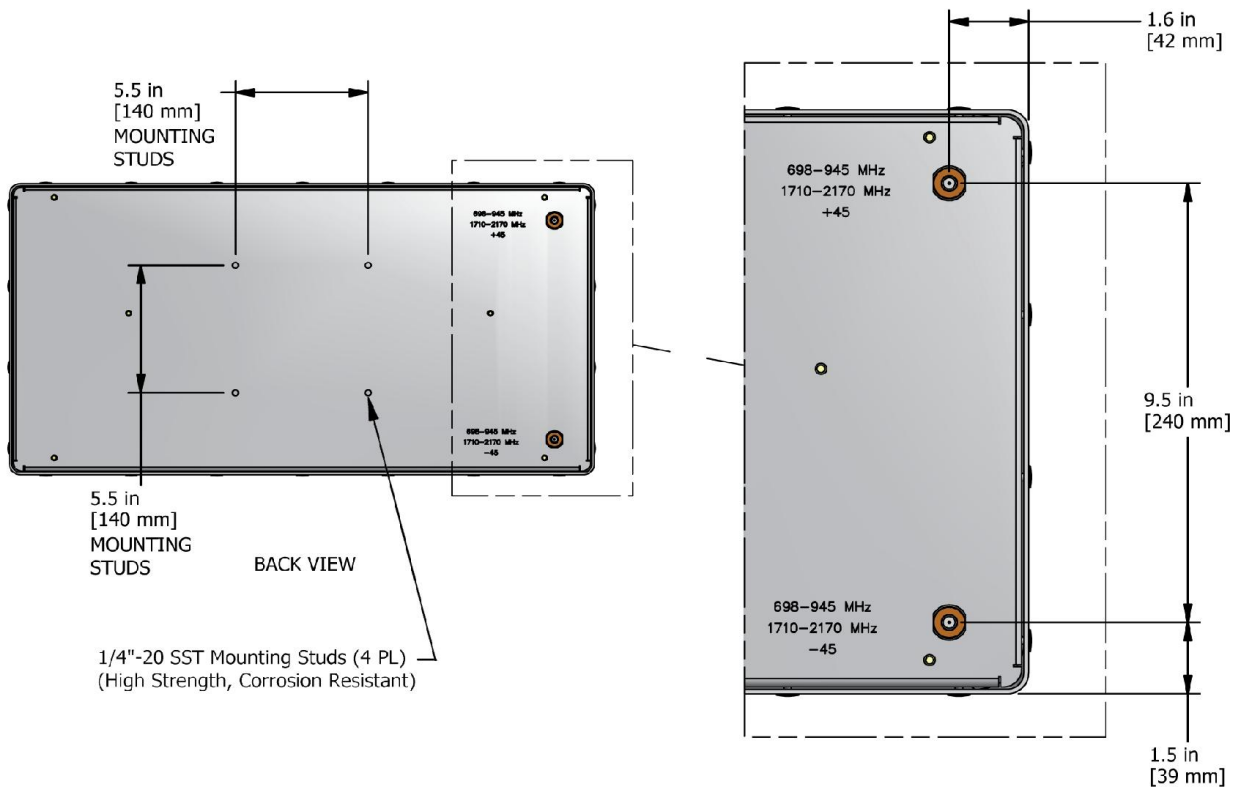

BACK VIEW

Standard Bracket Kit

www.cssantenna.com

410-612-0080

customerservice@cssantenna.com

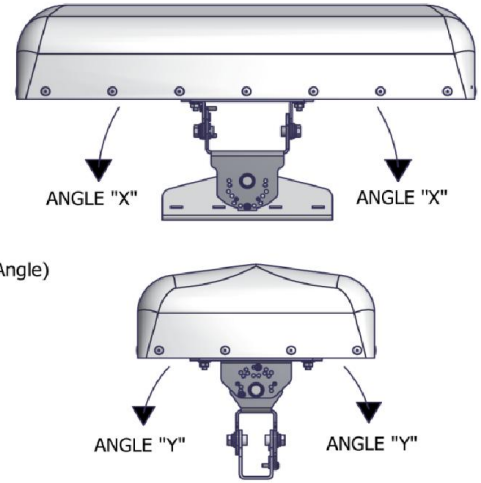
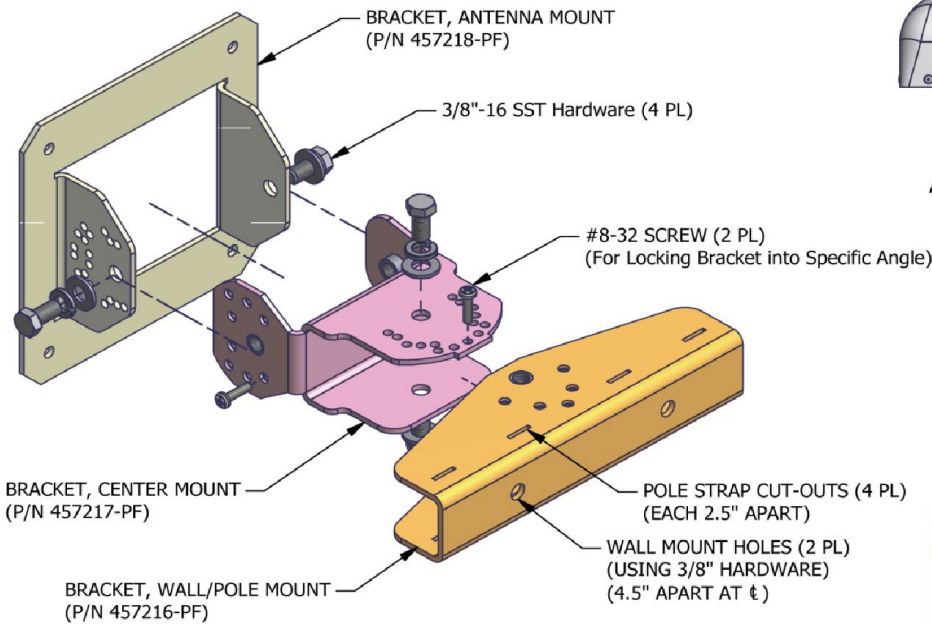

Maximum Angle				
	Pole Mount		Wall Mount	
Legend	X	Y	X	Y
1' Wide	35°	55°	35°	55°
2' Wide	25°	55°	25°	55°
3' Wide	20°	55°	20°	55°

Mech. Downtilt Table	
Legend	Mech. Downtilt
A	0°
B	5°
C	10°
D	15°
E	20°
F	25°
G	30°
H	35°
I	40°
J	45°
K	50°
L	55°

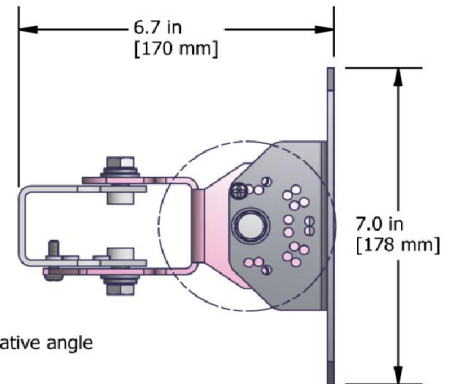
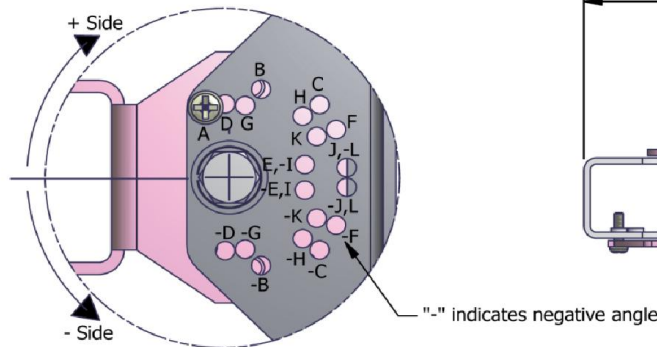

Mech. Downtilt Table	
Legend	Azimuth Rotation
A	0°
B	5°
C	10°
D	15°
E	20°
F	25°
G	30°
H	35°

