



DIFFERENT BY DESIGN™

JMA DAS Platform Next Generation Remote Units Installation Guide

Document Version: 7

Date: November 2024

jmawireless.com

Legal Notices

© 2024 John Mezzalingua Associates, LLC dba JMA Wireless. All rights reserved.

This document may contain confidential and/or proprietary information. All company names, brands, and logos are trademarks of holders JMA Wireless or its affiliates. All specifications are subject to change without notice.

World Headquarters

JMA Wireless

140 Cortland Ave.

Syracuse, NY 13202

+1 888 201-6073

customerservice@jmawireless.com

For additional contact information, see the JMA Wireless website:

www.jmawireless.com

Table of Contents

1 - About this Guide	5
1.1 - What's New	5
2 - Description of JMA Next Generation Remote Units	6
2.1 - Technical Specifications	7
2.2 - Physical Interfaces Description	8
2.3 - Protection Fuses	8
3 - Taking Delivery of Remote Units	9
3.1 - Original Packaging Description	9
4 - Installing Remote Units	10
4.1 - Installation Site Requirements	10
4.2 - Precaution and Warning Statements	10
4.3 - Fastening Next Generation Remote Units to the Wall	12
4.3.1 - Verification of Remote Unit Mounting	18
5 - Making Connections	19
5.1 - General Precaution and Warning Statements	19
5.2 - Connecting RF Cables	19
5.3 - Connecting the Remote Unit to the Master Unit	19
5.4 - Connecting Multiple Remote Units to the Master Unit Optical Transceiver using a Single Optical Fiber (DWDM)	22
5.5 - Connecting External Alarms	26
5.6 - Connecting AC Power Supply	28
5.7 - Connecting DC Power Supply	31
6 - Switching on the Remote Unit	33
7 - Setting Up and Managing the DAS	34
8 - Performing Preventive Maintenance	35
8.1 - Remote Units	35
8.2 - Optical Fiber	35
8.3 - Optical Connectors	35
9 - Replacing Faulty Components	37
9.1 - Replacing a Faulty Remote Unit	37
9.2 - Replacing a Faulty Fan Unit	38
10 - Compliance with the Technical Regulatory Standards	41
10.1 - Compliance with the EU and UK Regulatory Requirements	41
10.1.1 - EU Directive 2014/53/EU – RED (Radio Equipment Directive) and Radio Equipment Regulations 2017 (S.I. 2017/1206)	41

10.1.2 - EU Directive 2015/863/EU – RoHS (Restriction of the Use of certain Hazardous Substances)	43
10.1.3 - EU Directive 2012/19/EU – WEEE (Waste Electrical and Electronic Equipment)	43
10.1.4 - Packaging and Packaging Waste Directive 94/62/EC and Subsequent Amendments	43
10.2 - Compliance with FCC Rules and Regulations	45
10.2.1 - Radio Equipment Operating Frequency Bands: Commercial Bands	46
11 - Attachments	47
11.1 - Getting Help: Technical Support Contact Information	47
11.2 - Safety Rules	48
11.2.1 - Annex	50
11.3 - Warnings and Caution Statements	52
11.4 - Règles de Sécurité	56
11.4.1 - Annexe	58
11.5 - Mises en Garde et Déclarations de Précaution	60
11.6 - Symbols and Manufacture Labels Affixed to the Product	64
Abbreviations	66

1 - About this Guide

This document describes JMA next generation remote units and provides instructions to safely install, connect, power up the units, perform preventive maintenance, and replace faulty units or components. Remote units belong to the JMA DAS Platform, a multi-band, multi-operator architecture that provides a wide range of flexible and reliable solutions for cellular coverage and capacity distribution.

Each optical DAS is made up of two main elements, a **master unit** and **remote units**, connected with single mode optical fiber.

The **master unit**, sometimes also referred to as **modular headend**, is a rack-based modular platform that allows configurations for different needs and a future-proof design. It is connected to the signal source and hosts the supervision module for the management of the DAS components.

Remote units are self-contained and distributed throughout the territory to be served to provide signal distribution to a range of both indoor and outdoor antennas.

A single master unit supports all classes of remote units.

- For descriptions of the JMA master unit, refer to the *JMA DAS Platform Master Unit Installation Guide*.
- For descriptions of previous models of remote units, refer to the *JMA DAS Platform Remote Units Installation Guide*.

1.1 - What's New

This revision (rev. 7) of the *JMA DAS Platform Next Generation Remote Units Installation Guide* introduces the following changes:

- Clarified the "[Physical Interfaces Description](#)" on [page 8](#) to indicate that when the unit has not yet been discovered, the remote unit general operating status LED turns red.
- The procedure for connecting multiple remote units to the master unit optical transceiver using DWDM has been modified. See "[Connecting Multiple Remote Units to the Master Unit Optical Transceiver using a Single Optical Fiber \(DWDM\)](#)" on [page 22](#).

2 - Description of JMA Next Generation Remote Units

JMA next generation remote units are connected with single mode optical fiber to the next generation optical transceiver, installed in the master unit. Remote units are distributed throughout the territory to be served and provide RF signal distribution to a range of both indoor and outdoor antennas.

Next generation remote units and Software-Defined Remote Units (SDRU) can be single band or dual-band, AC powered or DC powered, with different RF power classes.

The operating bands and output power of Software-Defined Remote Units (SDRU) are tied to license keys that can be managed remotely using the JMA Wireless SDRU Panel software for real-time, non-service-affecting band and power upgrades.

Note: The fan unit is not equipped in single-band, 5W remote units.

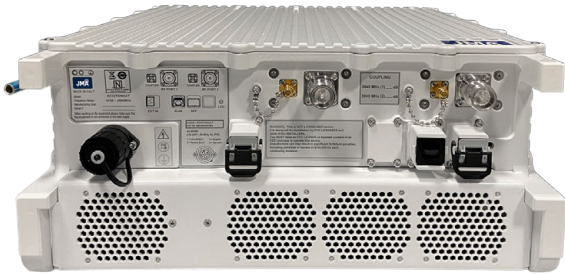

40W Remote Units and Software Defined Remote Units

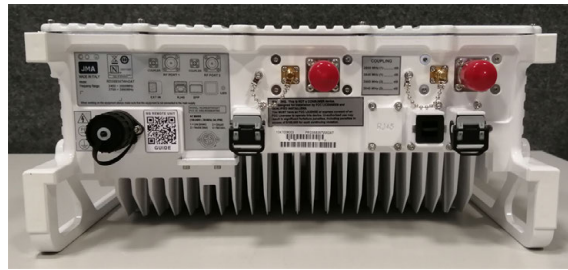

5W Remote Units

2 - Description of JMA Next Generation Remote Units

2.1 - Technical Specifications

The following table provides the electrical, environmental, and mechanical specifications for the JMA Next Generation, MIMO remote units:

Remote Unit Commercial Code	Operating Frequency Band(s)	Power Supply	Weight	Dimensions (HxWxD) max volume	Operating Temperature Range	IP Rating
RD35BWW2AT RD35BWX2AT	3450-3550MHz	AC voltage input: 100–240Vac nominal (range: 90 to 264Vac)	18.5kg (41lb)	453x405x198mm (17.8 x 15.9 x 7.8in) max volume - mounting bracket and optical port protection included.	-40°C to +55°C (-40°F to +131°F)	IP66
RD35TWW2AT RD35TWX2AT	3700-3980MHz					
RD35IWX2AT	3400-3800MHz					
RD35BWW2DT RD35BWX2DT	3450-3550MHz	DC voltage input: - 48Vdc nominal (range: -60 to -36Vdc)	18.5kg (41lb)	453x405x198mm (17.8 x 15.9 x 7.8in) max volume - mounting bracket and optical port protection included.	-40°C to +55°C (-40°F to +131°F)	IP66
RD35TWW2DT RD35TWX2DT	3700-3980MHz					
RD35IWX2DT	3400-3800MHz					
RD35B35TWX2AT RD35B35TWH2AT	3450-3550MHz and 3700-3980MHz	AC voltage input: 100–240Vac nominal (range: 90 to 264Vac)	19.7kg (43lb)	453x405x198mm (17.8 x 15.9 x 7.8in) max volume - mounting bracket and optical port protection included.	-40°C to +55°C (-40°F to +131°F)	IP66
			18.2kg (40lb)			
RD35B35TWX2DT RD35B35TWH2DT	3450-3550MHz and 3700-3980MHz	DC voltage input: - 48Vdc nominal (range: -60 to -36Vdc)	19.7kg (43lb)	453x405x198mm (17.8 x 15.9 x 7.8in) max volume - mounting bracket and optical port protection included.	-40°C to +55°C (-40°F to +131°F)	IP66
			18.2kg (40lb)			

Refer to the JMA DAS datasheets for detailed specifications. Contact JMA Sales Office for further information.

2 - Description of JMA Next Generation Remote Units

2.2 - Physical Interfaces Description

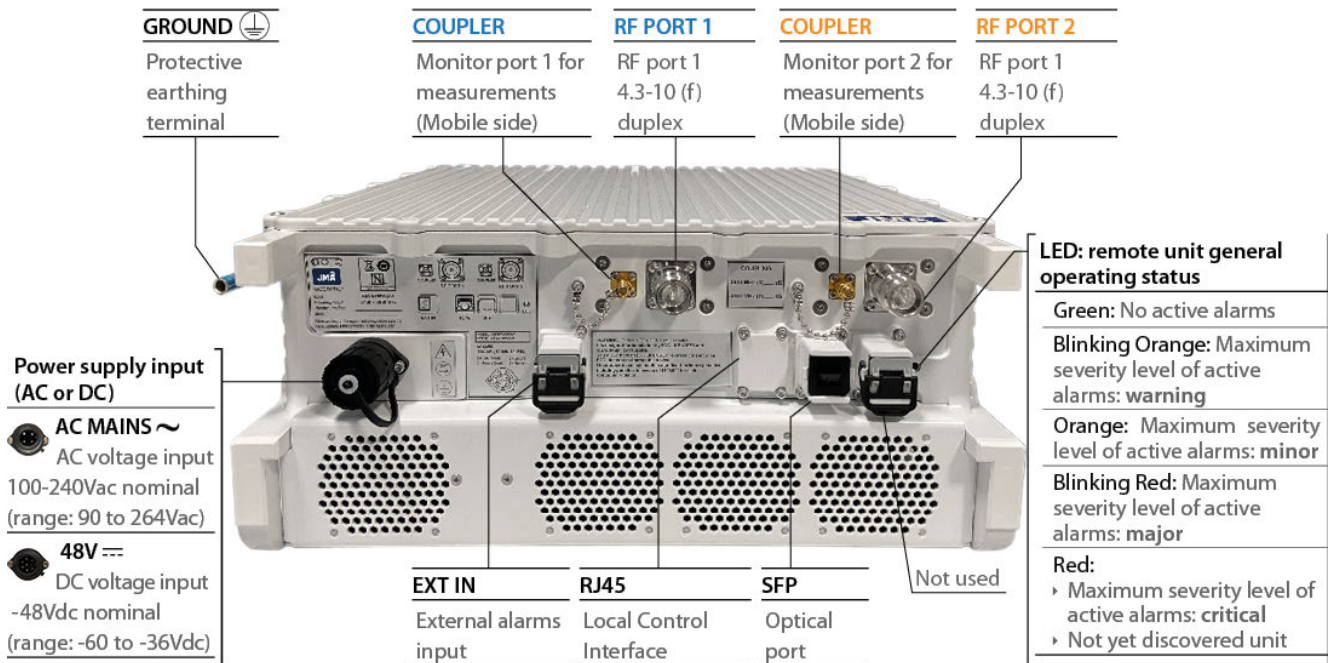

2.3 - Protection Fuses

Each remote unit final power amplifier is protected by a fuse. Protection fuses are **not** field-replaceable. Contact JMA Technical Support for details.

Caution: Opening the remote unit voids the warranty.

DC-powered Remote Units

The following figure shows the position and electrical rating of the protection fuse on the DC/DC power supply module:

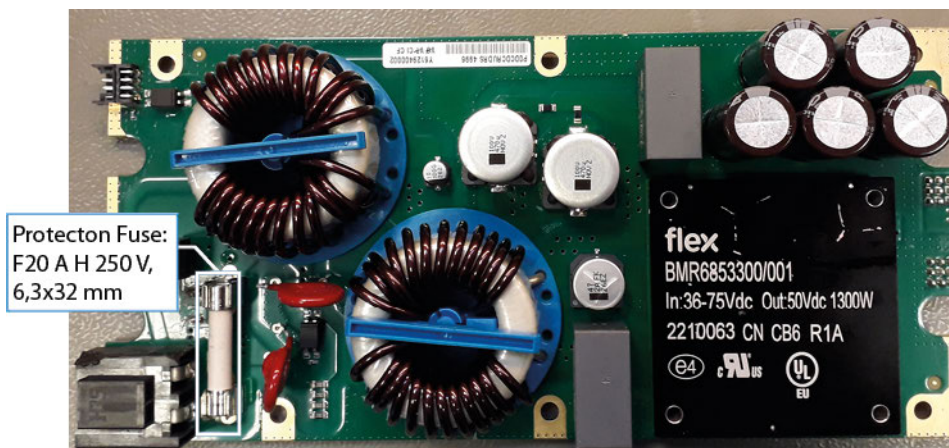

3 - Taking Delivery of Remote Units

Handling, Storing, Transporting, and Unpacking Guidelines

When taking delivery of JMA remote units, observe the following guidelines to avoid both personal injury and damage to the equipment:

- Transport the remote unit to the installation site and store it in the original packaging to reduce the risk of accidental damage.
- Check that there is adequate manpower to handle the remote units.
- During handling make sure that the directional arrows on the boxes always point upwards.
- To prevent damage from falling, do not place the unit on an unstable surface.
- Before removing the unit from the original packaging, make sure the installation site is safe and properly prepared. See ["Installation Site Requirements" on page 10](#).
- JMA remote units are carefully packaged to prevent damage during transportation. Carefully unpack the remote unit from the original packaging shortly before installation.
- Store the original packaging in case the unit must be returned or moved to a different location. Whenever a unit is to be transported or shipped for replacement or repair, it must be properly packaged to protect the equipment from drop, impact, vibrations, compressive loads, and atmospheric conditions. If the original material is not available, make sure to package the equipment in materials that provide an equivalent level of protection. See ["Original Packaging Description" on page 1](#).
- Review the supplied packing list and confirm that the list of materials that make up the equipment matches the equipment you receive. Should any components be missing, or should any be damaged, kindly inform the Sales Dept. of JMA immediately, to facilitate replacing and/or repairing of involved components.

Note: Each next generation remote unit includes two SFP28 optical transceivers:

- The SFP28 optical transceiver with the blue bail latch is pre-assembled inside the OCTIS™ plug kit for installation into the remote unit optical port.
- The SFP28 optical transceiver with the black bail latch must be delivered to the master unit site for installation into the optical port of the next generation optical transceiver to be connected to the remote unit. **Make sure that the SFP28 optical transceiver with the black latch is delivered to the master unit site.**

3.1 - Original Packaging Description

JMA remote units are carefully packaged to prevent damage during transportation.

Each remote unit is packed in a cardboard box. The equipment is wrapped inside a vacuum barrier bag and protected with foam-filled bags to reduce the risk of accidental damage.

4 - Installing Remote Units

Warning: It is important that before you start work on any equipment, you read the following:

- ["Safety Rules" on page 48](#)
- ["Installation Site Requirements" below](#)
- ["Precaution and Warning Statements" below](#)

4.1 - Installation Site Requirements

- Make sure that the installation site is safe, properly prepared, and air-conditioned to ensure that the equipment always operates in the proper temperature range: -40°C to +55°C (-40°F to +131°F).
- Ensure that the equipment is not exposed to direct sunlight at any time.
- Verify that the installation site meets the space and electrical requirements for the installation and operation of the equipment.
- Ensure that you have enough room to comfortably unpack the equipment without risking damage prior to installation.
- Provide enough spacing in front of the equipment for the installation and maintenance of the equipment and to allow enough air to circulate.

4.2 - Precaution and Warning Statements

- A correct system installation and setting procedure requires a good knowledge of and experience in installing telecommunication equipment.
- To ensure proper installation and configuration, these activities should be performed by skilled and experienced personnel only.
- Before you install the equipment, carefully read the safety rules attached to this document. See ["Safety Rules" on page 48](#).
- Before you start work on any equipment, make sure it is isolated from the power supply source.
- If not approved by JMA, repainting any components of the DAS voids the warranty.
- The equipment is intended to be installed in a Restricted Access Location (RAL) where the equipotential bonding has been applied. RAL is defined as a location for equipment where both of the following conditions apply:
 - Access can be gained only by SERVICE PERSONS or by USERS who have been instructed about the reasons for the restrictions applied to the location and about any precautions that shall be taken.
 - Access is gained using a TOOL or lock and key, or other means of security, and is controlled by the authority responsible for the location.

4 - Installing Remote Units

- In Denmark, Finland, Norway and Sweden, the equipment intended for connection to other equipment, or a network shall have a marking stating that the equipment must be connected to an earthed mains socket outlet.

In Finland: *"Laite on liitettävä suojakoskettimilla varustettuun pistorasiaan"*.

In Norway: *"Apparatet må tilkoples jordet stikkontakt"*.

In Sweden: *"Apparaten skall anslutas till jordat uttag"*.

In Denmark: *"Apparatets stikprop skal tilsluttes en stikkontakt med jord, som giver forbindelse til stikproppens jord"*.

4 - Installing Remote Units

4.3 - Fastening Next Generation Remote Units to the Wall

JMA next generation remote units are designed to be fastened to the wall, using the mounting bracket provided with the equipment.

Note: The unit must be installed in a vertical position, with the connector side facing downward.



Warning:

- Before you install the equipment, carefully read the ["Safety Rules" on page 48](#), the ["Installation Site Requirements" on page 10](#), and the ["Precaution and Warning Statements" on page 10](#).
- Verify that the remote unit is not connected to the power supply source and that the switch upstream of the unit is open.
- Fasteners are not provided with the remote unit. Make sure that the mounting hardware is suitable for the support (recommended hardware: 4xM8 hex screws, property class 8.8, minimum length 25mm).
- Verify that the mounting surface and fasteners can support four times the weight of the equipment.

Equipment Commercial Code	Weight
RD35BWW2AT, RD35BWW2DT, RD35BWX2AT, RD35BWX2DT RD35TWW2AT, RD35TWW2DT, RD35TWX2AT, RD35TWX2DT RD35IWX2AT, RD35IWX2DT	18.5kg (41lb)
RD35B35TWX2AT, RD35B35TWX2DT	19.7kg (43lb)
RD35B35TWH2AT, RD35B35TWH2DT	18.2kg (40lb)

- Verify there is adequate manpower to handle the remote unit.
- After installation, verify adequate mounting of the remote unit. See ["Verification of Remote Unit Mounting" on page 18](#).

4 - Installing Remote Units

Tools and materials

- 1 x next generation remote unit
- Wall-mount bracket (provided with the remote unit)
- 4 x M8X16 hex screws and 2 x M8 lock washers (provided with the remote unit)
- Mounting hardware suitable for the wall (not provided): recommend 4xM8 hex screws, property class 8.8, minimum length 25mm (0.98in)
- Drill, screwdriver (not provided)
- 13mm open-ended wrench (not provided)
- Level (not provided)

Mounting Procedure

1. Verify that the installation site meets the requirements described in "[Installation Site Requirements](#)" on page 10.
2. Choose a suitable location to install the remote unit. The following figure shows the overall dimensions of the remote unit and wall-mount bracket:

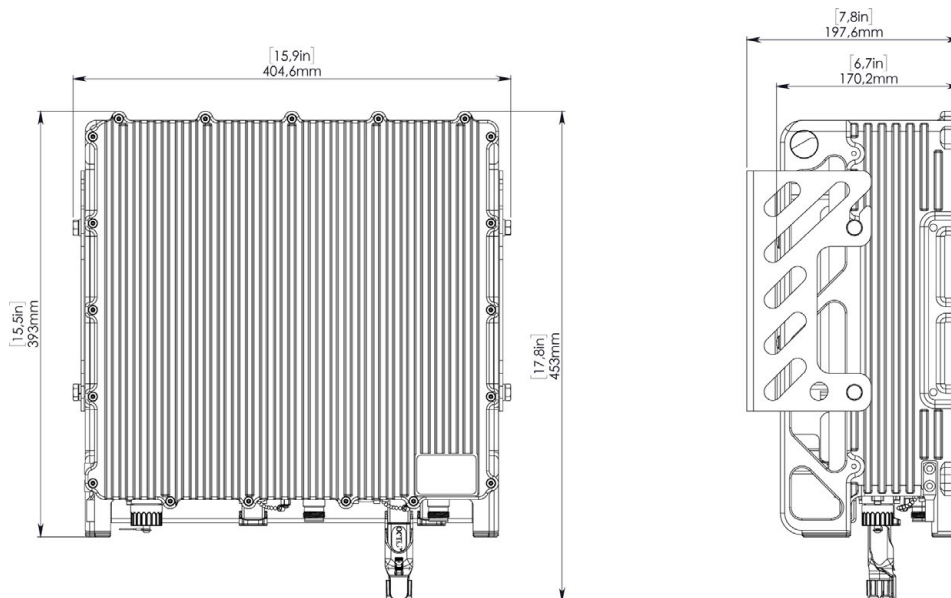

3. Unpack the equipment.

4 - Installing Remote Units

4. Remove the wall-mount bracket from the equipment and set the mounting hardware (2 x M8 lock washers and 4 x M8X16 hex screws) aside for later re-installation.

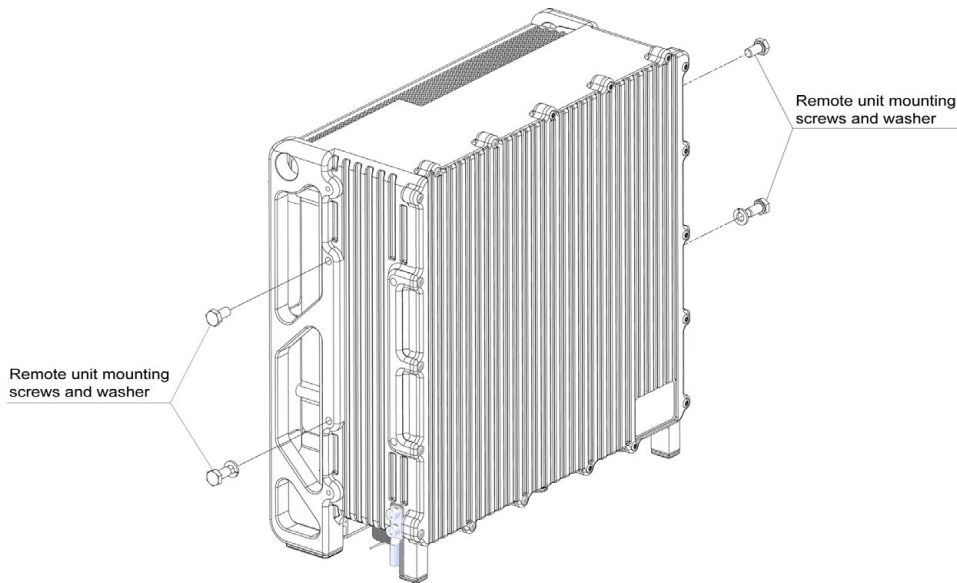

5. Securely fasten the wall-mount bracket to the wall, using a level and at least four fasteners.

- a Using the bracket as a template, mark the position of the mounting holes (at least four) on the wall. Make sure the bracket is level and oriented as shown in the picture below.

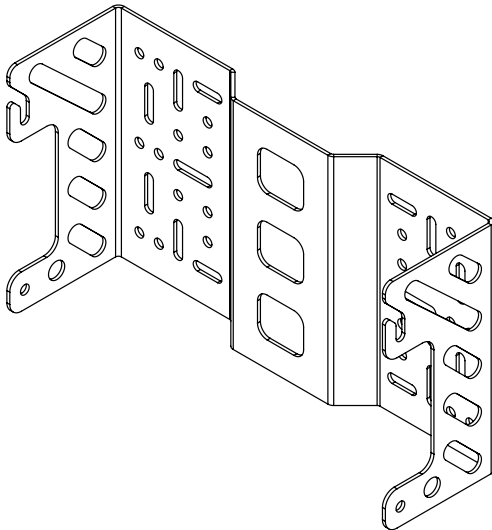

4 - Installing Remote Units

Note: The wall-mount bracket accommodates multiple mount hole patterns. You can select the hole pattern that best suits your installation needs as long as the selected mounting holes position ensures that the bracket is securely attached to the wall.

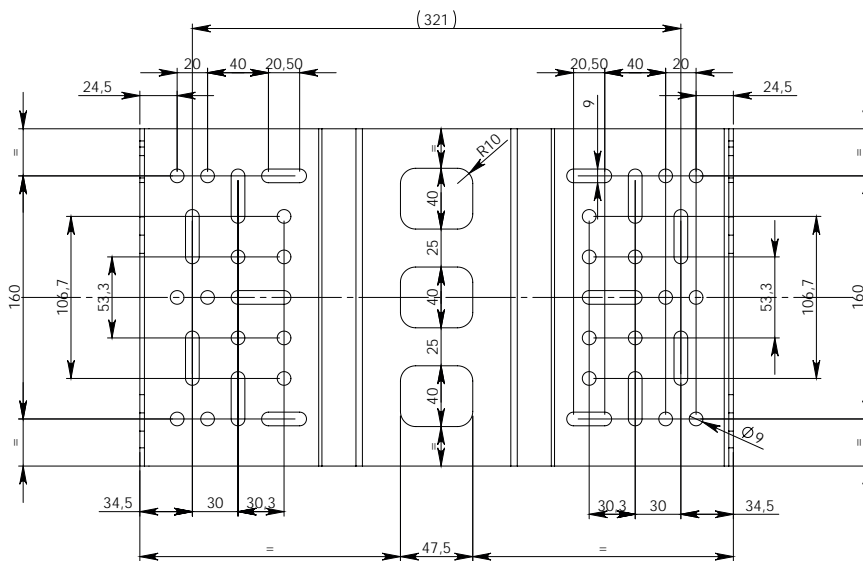

- b Drill four holes at the marked positions and insert wall anchors into the drilled holes.
- c Screw the wall mounting screws (not provided) through the bracket mounting holes into the anchors.

Note: Make sure that the mounting hardware can support the weight of the remote unit and that it is suitable for the mounting surface.

4 - Installing Remote Units

6. Fasten the remote unit to the wall-mounted bracket.

Use the two mounting holes on each side of the remote unit to secure the remote unit to the wall-mount bracket.

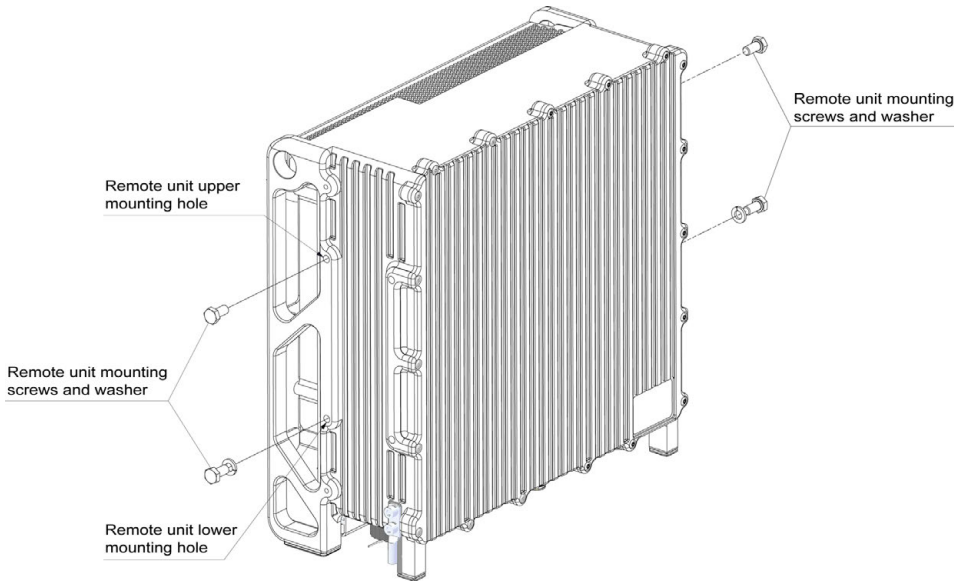

Use the four M8X16 hex screws and two M8 lock washers, previously removed, to fasten the equipment to the bracket, as follows:

- a Loosely install two M8X16 hex screws into the upper mounting holes, available on each side of the remote unit.

Note: Do not tighten the screws but leave enough distance from the remote unit for the bracket hanging slots to fit into the gap.

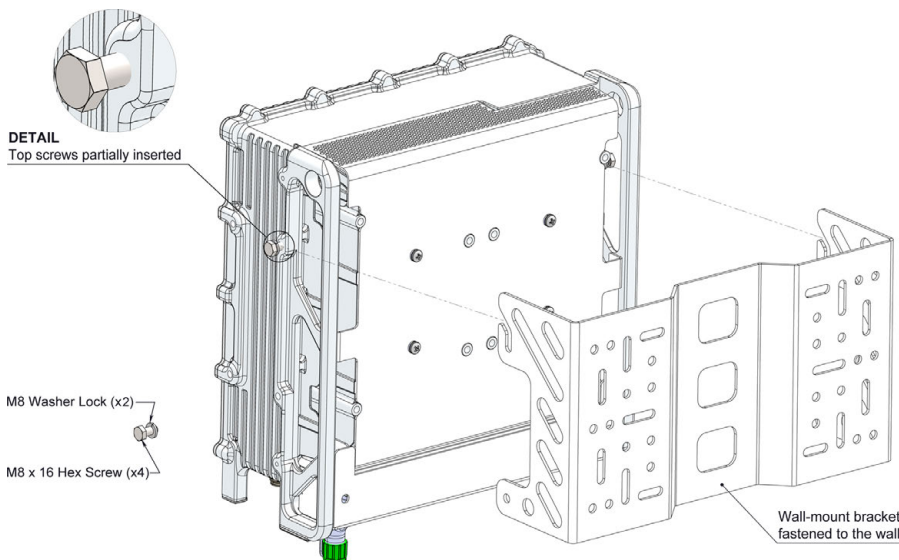

4 - Installing Remote Units

- b Lift the remote unit and hang it by inserting the two upper screws into the bracket hanging slots.

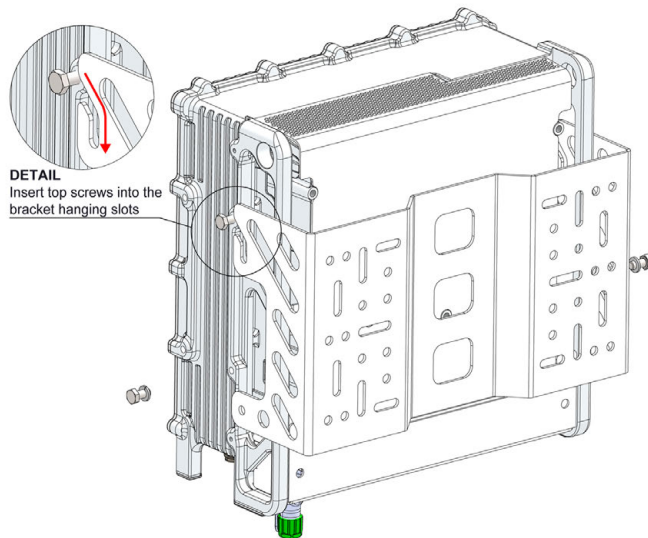

- c Ensure both screws are engaged in the slots.
- d Slide a lock washer on each of the other 2 x M8X16 hex screws, then fasten the equipment to the bracket using the 2 x M8X16 hex screws with washers: Insert the screws through the bracket lower mounting slots into the lower mounting holes on the sides of the remote unit.

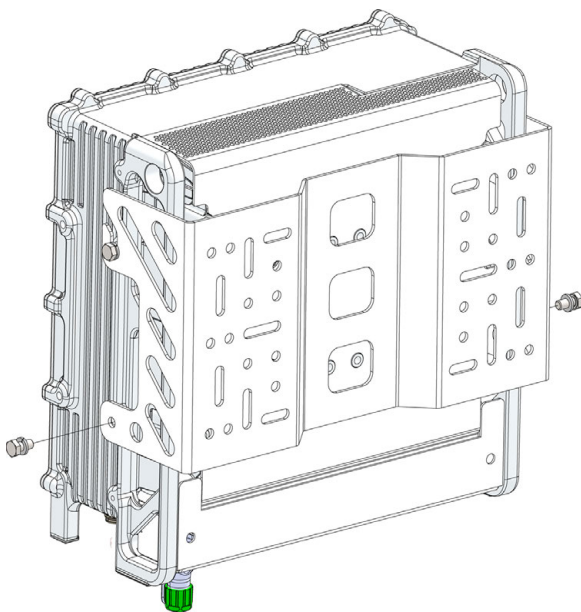

- e Fully tighten the four M8X16 hex screws to secure the remote unit to the bracket. Tighten each screw with a torque of 27Nm (20lbf-ft).

4 - Installing Remote Units

4.3.1 - Verification of Remote Unit Mounting

To verify adequate mounting of remote units, perform the following test:

1. Apply a force, in addition to the weight of the equipment, downwards through the center of gravity of the equipment, for one minute. The additional force shall be:
 - three times the weight of the equipment; or
 - the weight of the equipment plus 880N,whichever is less.
2. For equipment mounted to a wall or another structure, apply a horizontal force of 50N laterally for one minute.

Caution: Make sure to protect the equipment from falling in case the test fails.

5 - Making Connections

The following sections provide instructions to perform RF, optical, external alarms, and power supply connections.

Warning: It is important that before you start work on any equipment, you read the following:

- ["Safety Rules" on page 48](#)
- Specific precautions and warning statements provided in each procedure
- The following warnings

5.1 - General Precaution and Warning Statements

- Ethernet or coaxial ports that use a shielded cable must be shielded and grounded at both ends.
- Bare conductors must be coated with antioxidant before crimp connections are made.

5.2 - Connecting RF Cables

Connect the RF port(s) on the bottom of the remote unit to the antenna(s) providing coverage. Refer to the System design and to the ["Description of JMA Next Generation Remote Units" on page 6](#).

5.3 - Connecting the Remote Unit to the Master Unit

Next generation remote units are connected to the next generation optical transceiver, equipped in the master unit, with single mode optical fiber (LC-UPC/LC-UPC), with MIMO1 and MIMO2 uplink and downlink optical signals transmitted over the same optical fiber.

When dealing with optical fibers and connectors, it is important that you read the ["Safety Rules" on page 48](#) and observe the following precautions and warning statements:

Warning: When handling fiber optic devices, observe the following precautions:

- Never stare directly into fiber optic connectors and fibers. Invisible emitted laser beams can damage your eyes.
- Before you inspect and clean optical ports and connectors, always turn off the laser source.
- Never inspect a fiber while looking into it or connecting it to a fiber scope while the laser is on. Before inspection, always turn off the laser source.

Caution:

- Fiber optic devices are sensitive to static electricity. When handling static-sensitive devices, observe due precautions in handling them to prevent damage from electrostatic discharge.
- Always cover optical connectors, adapters, and optical ports with caps to prevent dust from accumulating on the interface. Remove fiber optic protective caps prior to making connections.

5 - Making Connections

- Before mating fiber optic connectors, inspect and clean the connectors and optical ports to ensure optimized performance.
- Optical connections must be made with care to avoid damaging the optical fiber or connectors.
- Do not bend fiber optic cable with a tight radius of curvature; the cable might be damaged and losses within the fiber might occur.

See "[Optical Connectors](#)" on page 35 for cleaning procedures.

Note: Each remote unit is delivered with two SFP28 optical transceivers:

- The SFP28 optical transceiver with the **blue** bail latch is pre-assembled inside the OCTIS™ plug kit and must be installed into the remote unit optical port.



- The SFP28 optical transceiver with the **black** bail latch must be delivered to the master unit site for installation into the optical port of the next generation optical transceiver to be connected to the remote unit. **Make sure the transceiver with the black latch is delivered to the master unit site.**

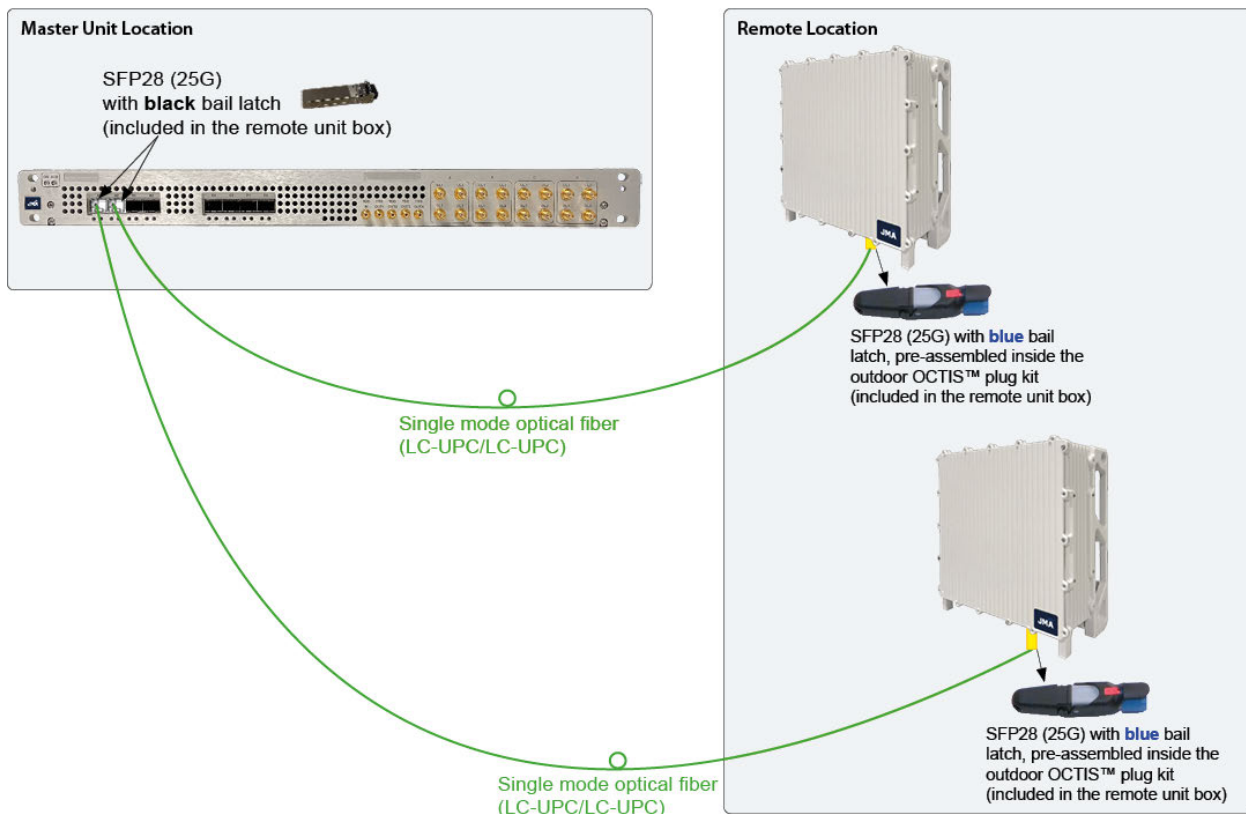

Connect the optical cable from the next generation transceiver to the remote unit SFP28 optical port as described in the following steps:

1. Follow the instructions provided with the OCTIS™ plug kit to remove the SFP28 holder from the plug kit.

5 - Making Connections

2. Follow the instructions provided with the OCTIS™ plug kit to correctly connect the optical cable from the next generation optical transceiver to the SFP28 optical transceiver inside the SFP28 holder, and to properly protect the optical connection.

Note: Make sure you connect:

- JMA next generation single-band remote units to JMA next generation single-band optical transceivers operating in the same band.
- JMA next generation dual-band remote units to JMA next generation dual-band optical transceivers operating in the same bands.

The following table details the next generation optical transceivers and remote units operating frequency bands:

Operating Frequency Band(s)	Optical Transceiver Commercial Code	Remote Unit Commercial Codes
3700–3980MHz	ED35TD	RD35TWW2AT, RD35TWX2AT RD35TWW2DT, RD35TWX2DT
3450–3550MHz	ED35BD	RD35BWW2AT, RD35BWX2AT RD35BWW2DT, RD35BWX2DT
3400–3800MHz	ED35ID	RD35IWX2AT, RD35IWX2DT
3450–3550MHz and 3700–3980MHz	ED35B35TD	RD35B35TWX2AT, RD35B35TWX2DT RD35B35TWH2AT, RD35B35TWH2DT

3. Remove the remote unit SFP28 port protective cap.

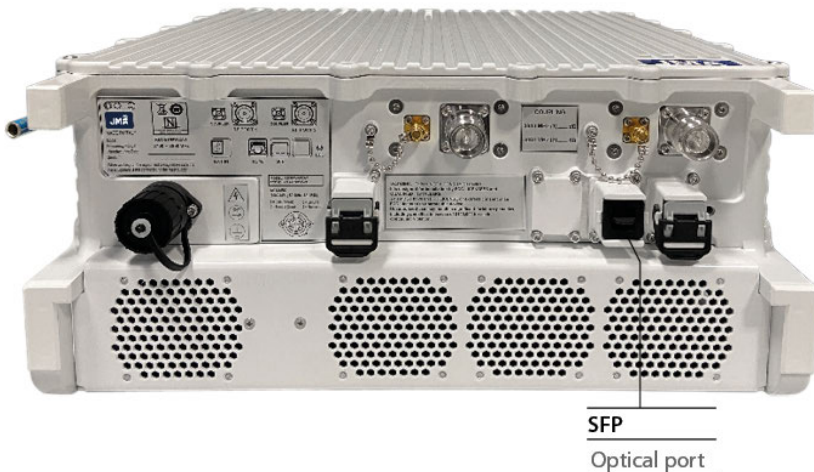

4. Remove the plug kit cap, then insert the SFP28 transceiver, protected by the kit, into the SFP port.

5. Close the OCTIS™ plug kit lever, then slide the locking mechanism to the locked position to secure and seal the connection.

Caution: When connecting optical fibers to remote units, **always protect the SFP28 transceiver with the OCTIS™ plug kit provided with the remote unit** to properly seal the optical connection and ensure the IP66 rating provided by the equipment enclosure.

5 - Making Connections

5.4 - Connecting Multiple Remote Units to the Master Unit Optical Transceiver using a Single Optical Fiber (DWDM)

You can connect the next generation optical transceiver to multiple next generation remote units with a single optical fiber, using the JMA optional DWDM kits and the JMA Dense Wavelength Multiplexers/Demultiplexers (TFO-MUX/DEMUX) to allow the simultaneous transmission of multiple DWDM optical channels over the connecting optical fiber.

Note: The ED35TD and ED35BD next generation optical transceivers do not support Dense Wavelength Division Multiplexing (DWDM).

Each JMA optional DWDM kit includes 2 x SFP28 optical transceivers. The color of the bail latch on each optical transceiver identifies the SFP28 operating DWDM channel, as detailed in the following table:

Optional DWDM kit	Color of the bail latch of the SFP28+ Optical Transceiver	SFP28+ Operating DWDM ITU channel	Installation side of the SFP28+ Optical Transceiver	Ports on the Optical Transceiver	MUX/DEMUX Ports to connect
ED-DWDM2325-KIT	Red	23	Master Unit	TX	DL Ch23 (Master TFO-MUX/DEMUX)
				RX	UL Ch25 (Master TFO-MUX/DEMUX)
	Brown	25	Remote Unit	TX	UL Ch25 (Remote TFO-MUX/DEMUX)
				RX	DL Ch23 (Remote TFO-MUX/DEMUX)
ED-DWDM2729-KIT	Grey	27	Master Unit	TX	DL Ch27 (Master TFO-MUX/DEMUX)
				RX	UL Ch29 (Master TFO-MUX/DEMUX)
	Yellow Green	29	Remote Unit	TX	UL Ch29 (Remote TFO-MUX/DEMUX)
				RX	DL Ch27 (Remote TFO-MUX/DEMUX)
ED-DWDM3133-KIT	Black	31	Master Unit	TX	DL Ch31 (Master TFO-MUX/DEMUX)
				RX	UL Ch33 (Master TFO-MUX/DEMUX)
	Yellow Orange	33	Remote Unit	TX	UL Ch33 (Remote TFO-MUX/DEMUX)
				RX	DL Ch31 (Remote TFO-MUX/DEMUX)
ED-DWDM3537-KIT	Silver	35	Master Unit	TX	DL Ch35 (Master TFO-MUX/DEMUX)
				RX	UL Ch37 (Master TFO-MUX/DEMUX)
	Blue	37	Remote Unit	TX	UL Ch37 (Remote TFO-MUX/DEMUX)
				RX	DL Ch35 (Remote TFO-MUX/DEMUX)
ED-DWDM3941-KIT	White	39	Master Unit	TX	DL Ch39 (Master TFO-MUX/DEMUX)
				RX	UL Ch41 (Master TFO-MUX/DEMUX)
	Sky Blue	41	Remote Unit	TX	UL Ch41 (Remote TFO-MUX/DEMUX)
				RX	DL Ch39 (Remote TFO-MUX/DEMUX)
ED-DWDM4345-KIT	Beige	43	Master Unit	TX	DL Ch43 (Master TFO-MUX/DEMUX)
				RX	UL Ch45 (Master TFO-MUX/DEMUX)
	Green	45	Remote Unit	TX	UL Ch45 (Remote TFO-MUX/DEMUX)
				RX	DL Ch43 (Remote TFO-MUX/DEMUX)

5 - Making Connections

Procedure:

Connect the DAS components as follows:

1. Make sure that the DWDM support is enabled at both ends of the connecting optical fiber. In the *JMA DAS Platform Remote Monitoring and Management User Guide*, refer to *Enabling and Disabling Dense Wavelength Division Multiplexing (DWDM)* for details.
2. Refer to the table above to identify the installation side of the DWDM optical transceivers.
3. Master unit side: Insert one SFP28 optical transceiver into each optical port of the Next Generation Dual-Band Optical Transceiver to be connected to remote units as follows:
 - a Shortly before installation, remove the SFP28 optical transceiver from its box, then remove the protective cap from the transceiver optical connector receptacle.
 - b Correctly align the SFP28 optical transceiver with the optical port.
 - c Gently press the SFP28 optical transceiver into the port until it snaps into place.
4. Master unit side: Connect the DWDM optical transceivers to the master TFO-MUX/DEMUX using single mode optical fiber (LC-UPC/SC-APC). Refer to the table above to correctly connect the DWDM optical transceiver ports to the master JMA TFO-MUX/DEMUX ports.
5. Remote unit side: Follow the instructions provided with the OCTIS™ plug kit to correctly mount the SFP28 optical transceiver inside the OCTIS™ plug kit and to correctly connect the SFP28 optical transceiver to the remote TFO-MUX/DEMUX. Use single mode optical fiber (LC-UPC/SC-APC).

Refer to the table above to correctly connect the DWDM optical transceiver ports to the remote JMA TFO-MUX/DEMUX ports.



Caution: When connecting optical fibers to remote units, **always protect the SFP28 optical transceiver with the OCTIS™ plug kit** to properly seal the optical connection and ensure the IP66 rating provided by the equipment enclosure.

6. Connect the common ports of the master and remote TFO-MUX/DEMUX with single mode optical fiber (SC-APC/SC-APC).

Note: Make sure you connect:

- JMA next generation single-band remote units to JMA next generation single-band optical transceivers operating in the same band.
- JMA next generation dual-band remote units to JMA next generation dual-band optical transceivers operating in the same bands.

5 - Making Connections

Example: Connecting ED35B35TD and RD35B35TWX2AT using the JMA TFO-MUX/DEMUX and the Optional ED-DWDM2325-KIT

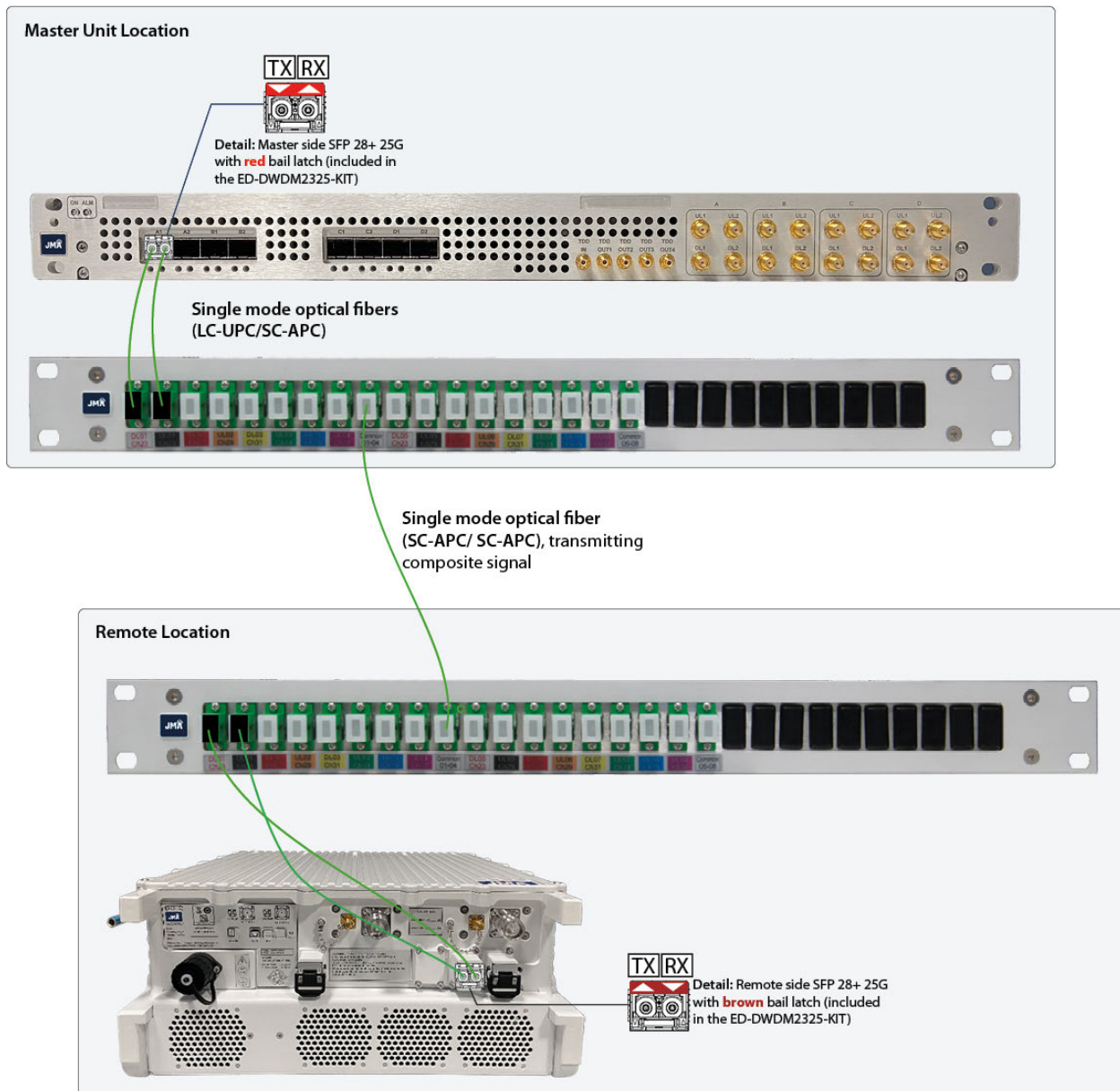

1. Access the web interface of the DAS supervision module which manages the DAS components and make sure that DWDM is enabled. Refer to the *JMA DAS Platform Remote Monitoring and Management User Guide* for details.
2. Check the table to identify the installation side of the DWDM optical transceivers inside the optional **ED-DWDM2325-KIT**:

Optional DWDM kit	Color of the bail latch of the SFP28 Optical Transceiver	SFP28 Operating DWDM ITU channel	Installation side of the SFP28 Optical Transceiver	Ports on the Optical Transceiver	MUX/DEMUX Ports to connect
ED-DWDM2325-KIT	Red	23	Master Unit (ED35B35TD)	TX	DL Ch23 (Master TFO-MUX/DEMUX)
				RX	UL Ch25 (Master TFO-MUX/DEMUX)
	Brown	25	Remote Unit	TX	UL Ch25 (Remote TFO-MUX/DEMUX)
				RX	DL Ch23 (Remote TFO-MUX/DEMUX)

5 - Making Connections

3. Master unit side: Insert the DWDM SFP28 with the **red** bail latch into the **ED35B35TD** optical port.

Insert the optical transceiver as follows:

- a Shortly before installation, remove the SFP28 optical transceiver from its box, then remove the protective cap from the transceiver optical connector receptacle.
 - b Correctly align the SFP28 optical transceiver with the optical port.
 - c Gently press the SFP28 optical transceiver into the port until it snaps into place.
4. Master unit side: Connect the DWDM optical transceiver to the master TFO-MUX/DEMUX using single mode optical fiber (LC-UPC/SC-APC):
 - a Connect the SFP28 **TX** port to the **DL Ch23** port on the TFO-MUX/DEMUX.
 - b Connect the SFP28 **RX** port to the **ULCh25** port on the TFO-MUX/DEMUX.
 5. Remote Unit side: Follow the instructions provided with the OCTIS™ plug kit to mount the DWDM SFP28 with the **brown** bail latch inside the OCTIS™ plug kit and to correctly connect the DWDM optical transceiver to the remote TFO-MUX/DEMUX using single mode optical fiber (LC-UPC/SC-APC):
 - a Connect the SFP28 **TX** port to the **UL Ch25** port on the TFO-MUX/DEMUX.
 - b Connect the SFP28 **RX** port to the **DL Ch23** port on the TFO-MUX/DEMUX.

Caution: Follow the instructions provided with the OCTIS™ plug kit to properly protect the optical connection.
 6. Connect the common ports of the master and remote TFO-MUX/DEMUX with single mode optical fiber(SC-APC/ SC-APC).

Note: Make sure you connect:

 - JMA next generation single-band remote units to JMA next generation single-band optical transceivers operating in the same band.
 - JMA next generation dual-band remote units to JMA next generation dual-band optical transceivers operating in the same bands.

5 - Making Connections

5.5 - Connecting External Alarms

The external alarms input connector (EXT IN) provides four dry contacts to monitor alarms generated by external devices.

The optional external alarms connection kit (RDALCA) is available to connect external alarms to the remote unit. The optional RDALCA external alarms connection kit, to be ordered separately, includes the OCTIS™ plug kit and two-meter cable.

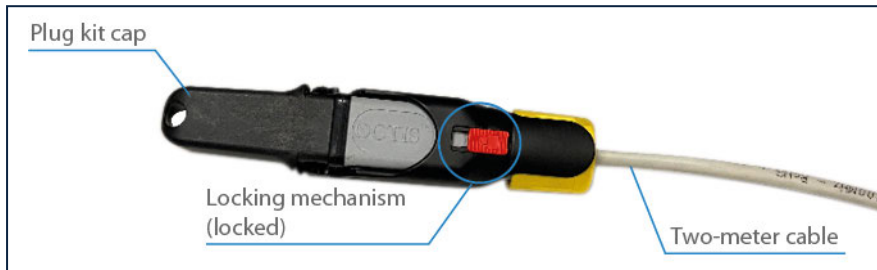

1. Connect the RDALCA to the remote unit as follows:

- a Remove the remote unit EXT IN port protective cap.
- b Slide the locking mechanism on the OCTIS™ plug kit to the unlocked position, then lift the locking lever up.

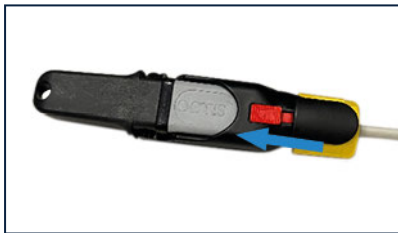

Locking mechanism in the unlocked position



Locking lever up

- c Remove the plug kit cap, then insert the plug connector into the EXT IN socket.
- d Close the OCTIS™ plug kit lever, then slide the locking mechanism to the locked position to secure and seal the connection.

5 - Making Connections

2. Connect external alarms. Refer to the following figure for details about the EXT IN connector dry contacts:

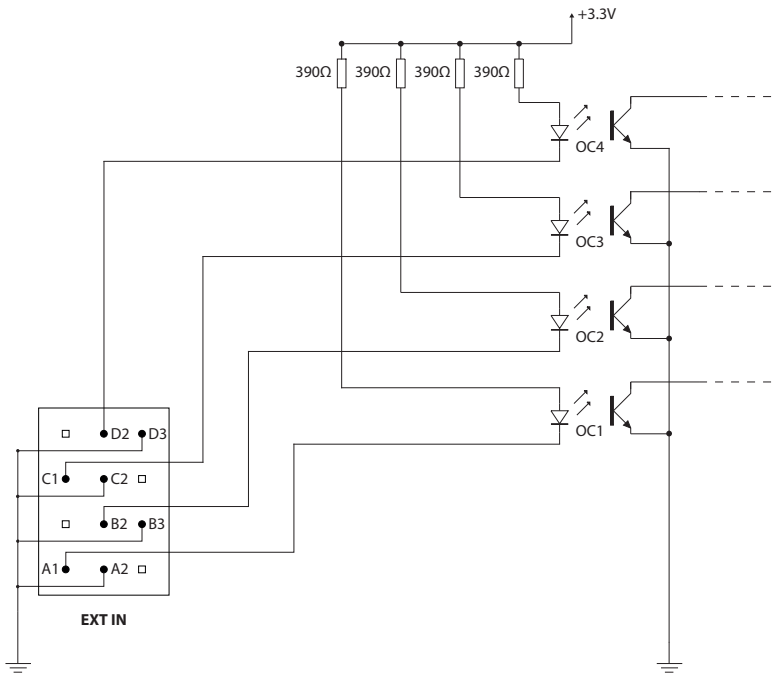

3. Access the DAS supervision module web interface to configure and enable external alarms. Refer to the *JMA DAS Platform Local Commissioning User Guide* for details.

5 - Making Connections

5.6 - Connecting AC Power Supply

This section describes how to connect the JMA AC-powered remote units to an external, customer-provided AC power source.

It is important that before you start work on any equipment, you read the ["Safety Rules" on page 48](#) and the following precaution and warning statements.

Warning:

- Before you start work on any equipment, make sure it is isolated from the power supply source.
- Make sure that the power supply source provides the nominal voltage prescribed.
- Equipment shall be connected to an earthed socket-outlet. Earthing connection of the socket-outlet requires verification by a skilled person.
- The equipment can be connected to an IT power distribution system.
- The following are the AC power supply cord requirements:
 - If it is necessary to fit an AC power supply plug to a power cable, you must observe the standard wire coloring in the country of installation.
You must also ensure that the protective earth wire would be the last to break if the cable is subject to excessive strain.
 - The detachable AC power supply cord set shall be no lighter than light PVC sheathed flexible cord (H03VV-F) for indoor installation and rubber (H07RN-F) or PVC (SJTW, for the United States and Canada only) for outdoor installation, according to IEC60227, UL 817 for the United States, and CSA C22.2 No.21 for Canada.
 - The detachable AC power supply cord set shall comply with the following requirements:
 - nominal voltage 240Vac
 - maximum operating temperature $\geq 60^{\circ}\text{C}$ (140°F)
 - For US/Canada market:
 - Minimum cord length is 1.5m.
 - If used in ITE Rooms, power supply cords must be no longer than 4.5m.
 - Flexible power supply cords must be compatible with Article 400 of the NEC and Tables 11 and 12 of the CEC.
 - Power supply cords for outdoor equipment must be suitable outdoor use type as required by Section 400.4 of the NEC and Rule 4-012 of the CEC, that is, marked water resistant, outdoor, W or W-A.
 - Power supply cords must have attachment plugs rated not less than 125 percent of the rated current of the equipment.
- Since the plug on the power supply cord is intended to serve as the disconnect device, the socket-outlet shall be installed near the equipment and shall be easily accessible.

5 - Making Connections

Caution: JMA strongly recommends that you install a thermal magnetic circuit breaker upstream of the system.

5 - Making Connections

Connect the AC-powered remote unit to the AC power supply as follows:

1. Make sure that the switch upstream of the remote unit is open.
2. Connect the remote unit to the nearest ground reference location.

The grounding lug, grounding socket head screws (2 x M6x8mm), and lock washers (2 x M6) for the equipment grounding are located on the side of the remote unit and can be identified by the ground symbol.

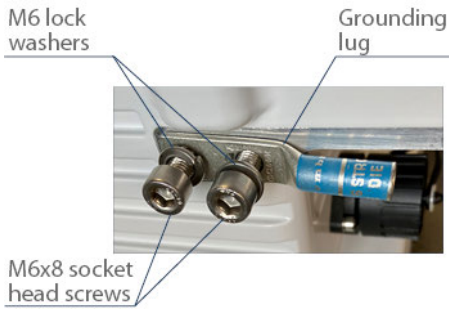

The grounding conductor gauge is AWG 6, with color compliant with the standard wire coloring in the country of installation.

3. Make sure that the power supply source provides the AC voltage prescribed: 100-240Vac nominal (range: 90 to 264Vac).
4. Connect the AC power supply cord to the remote unit power supply input.

Note: The recommended gauge of the AC power supply cord is AWG18-14.

AC MAINS connector pin assignment



PIN	Connection	Color
1	Line	Brown
2	Neutral	Blue
3	Ground (GND)	Yellow/green
4	Not connected	

5 - Making Connections

5.7 - Connecting DC Power Supply

This section describes how to connect the JMA DC-powered remote units to an external, customer-provided DC power source.

It is important that before you start work on any equipment, you read the ["Safety Rules" on page 48](#) and the following warning statements.

Warning:

- Before you start work on any equipment, make sure it is isolated from the power supply source.
- Make sure that the power supply source provides the nominal voltage prescribed.
- When installing the DC power supplied equipment, you must connect the positive terminal of the DC mains supply to protective earth, Common DC Return (DC-C) configuration.
- According to the manufacturer, the DC powered remote unit shall be installed in an isolated secondary circuit, which is separated from the primary circuit by reinforced or double insulation.
- The following are the DC power supply cord requirements:
 - The color of the wires inside the power cord should be compliant with the standard wire coloring in the country of installation.
 - The detachable DC power supply cord set must meet the requirements for indoor or outdoor use, in accordance with the standards of the country of installation.
 - The detachable DC power supply cord set shall comply with the following requirements:
 - nominal voltage 72Vdc
 - maximum operating temperature $\geq 75^{\circ}\text{C}$ (167°F)
 - For US/Canada market:
 - Minimum cord length is 1.5m, with certain constructions (such as external power supplies) allowed to consider both input and output cord lengths into the requirement.
 - Power supply cords must be no longer than 4.5m, if used in ITE Rooms.
 - Flexible power supply cords must be compatible with Article 400 of the NEC and Tables 11 and 12 of the CEC.
 - Power supply cords for outdoor equipment must be suitable outdoor use type as required by Section 400.4 of the NEC and Rule 4-012 of the CEC, that is, marked water resistant, outdoor, W or W-A.
 - Power supply cords must have attachment plugs rated not less than 125 percent of the rated current of the equipment.
- The Vdc input connector is the means to disconnect the equipment from DC mains supply. Remove it to disconnect the equipment from power supply source before operation.

5 - Making Connections

- You must provide an external protective device from overcurrent (50A, 250V). The protective device should be compliant with the standards of the country of installation.
- The equipment is intended and designed to be connected to a DC power source with a maximum transient voltage up to 1.5kV.

Connect the DC-powered remote unit to the DC power supply as follows:

1. Make sure that the switch upstream of the remote unit is open.
2. Connect the remote unit to the nearest ground reference location.

The grounding lug, grounding socket head screws (2 x M6x8mm), and lock washers (2 x M6) for the equipment grounding are located on the side of the remote unit and can be identified by the ground symbol.

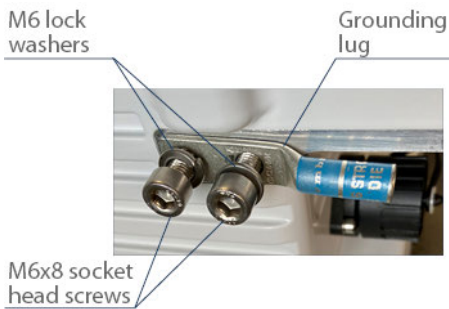

The grounding conductor gauge is AWG 6, with color compliant with the standard wire coloring in the country of installation.

3. Make sure that the power supply source provides the DC voltage prescribed:
- 48Vdc nominal (range: -60 to -36Vdc).
4. Connect DC power.

Note: The gauge of the DC power supply cord is 6xAWG16 (three used for positive pole and three used for negative pole).

DC voltage input connector pin assignment

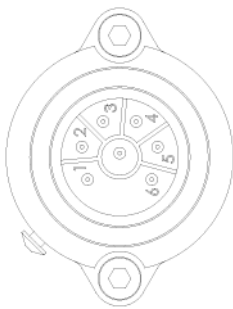

PIN	Connection
1	Positive
2	Positive
3	Positive
4	Negative
5	Negative
6	Negative

6 - Switching on the Remote Unit

Caution: To prevent damages to the equipment, before power-up, make sure that the DAS RF interfaces (POIs or TDFEs) are **not** connected to the signal source.

1. Close the switch upstream of the unit.
2. Verify that the general operating status LED on the remote unit turns on to indicate that the remote unit is powered up.

If the LED is turned off, check power supply connections.

3. Access the DAS supervision module web interface to identify or verify the correct identification of the unit. Refer to the following user guides for details:

- *JMA DAS Platform Remote Monitoring and Management User Guide*
- *JMA DAS Platform Local Commissioning User Guide*

7 - Setting Up and Managing the DAS

After power-up, the configuration and management of the remote unit is performed by connecting to the DAS supervision module web interface.

Refer to the following guides for details:

- *JMA DAS Platform Local Commissioning User Guide*
- *JMA DAS Platform Remote Monitoring and Management User Guide*

8 - Performing Preventive Maintenance

This section provides the recommended preventive maintenance procedures.

Preventive maintenance consists of scheduling routine maintenance of equipment to ensure optimal working conditions, thus preventing problems that might lead to equipment failure.

Warning: It is important that before you start work on any equipment, you read the following:

- ["Safety Rules" on page 48](#)
- General precautions and warning statements referenced in each procedure
- Specific precautions and warning statements provided in each procedure

8.1 - Remote Units

When remote units are installed in a dirty environment, a periodic visual check is recommended to guarantee maximum efficiency of the cooling system.

If necessary, clean the rear heat sink and the fan unit, when equipped, using compressed air to blow dirt away (blow from bottom upwards).



Warning: Hot Surface

The heat sink could reach dangerous temperatures. Do not touch! Contact with the heat sink surface may cause burns. Allow the surface to cool before servicing.

8.2 - Optical Fiber

It is best practice to periodically check the integrity of the optical fiber.

8.3 - Optical Connectors

Dirty connector end faces can cause degradation of optical signals. Before mating, inspect and clean fiber optic connectors and optical ports to ensure optimal performance.

It is important that before you inspect and clean fiber optic cables and connectors, you read the following precautions and warning statements:

Warning: When handling fiber optic devices, observe the following precautions:

- Never stare directly into fiber optic connectors and fibers. Invisible emitted laser beams can damage your eyes.
- Before you inspect and clean optical ports and connectors, always turn off the laser source.
- Never inspect a fiber while looking into it or connecting it to a fiber scope while the laser is on. Before inspection, always turn off the laser source.

Caution:

- Fiber optic devices are sensitive to static electricity. When handling static-sensitive devices, observe due precautions in handling them to prevent damage from electrostatic discharge.

8 - Performing Preventive Maintenance

- Always cover optical connectors, adapters, and optical ports with caps to prevent dust from accumulating on the interface. Remove fiber optic protective caps prior to making connections.
- Before mating fiber optic connectors, inspect and clean the connectors and optical ports to ensure optimized performance.
- Optical connections must be made with care to avoid damaging the optical fiber or connectors.
- Do not bend fiber optic cable with a tight radius of curvature; the cable might be damaged and losses within the fiber might occur.

Procedures:

▪ Inspection

You can use a fiber optic microscope (optical fiber scope) to detect scratches, dirt, dust, and other contaminants on optical connector end faces.

Warning: Before inspection, always turn off the laser source.

▪ Cleaning

For fiber optic cleaning, JMA recommends dry-cleaning methods that do not use solvent. The following methods are recommended to clean fiber optic ends and optical connector end faces.

▸ Reel cleaner (pigtailed devices)

Fiber optic reel cleaner is a reliable dry-cleaning method that ensures uniform results. It is a moderately abrasive fiber optic cleaning method.

Cleaning procedure:

Warning: Before cleaning optical fiber, make sure that the laser source is off.

1. Remove the fiber optic protective cap.
2. Push and hold the reel cleaner lever to expose the 2-micron fiber cleaning cloth.
3. Press lightly and rub the connector tip downward.

▸ Stick cleaners

Sticks are designed for dry cleaning of fiber optic connector mating sleeves, bulkhead adapters, and receptacles. They are used to clean the end face of connectors already installed in patch panels and hardware devices.

Cleaning procedure:

Warning: Before cleaning optical fiber, make sure that the laser source is off.

Caution: Never reuse a stick.

1. Insert the stick into the bulkhead adapter or receptacle.
2. Make the tip contact the connector end face.
3. Rotate the stick applying a light vertical force.
4. Pull the stick out and dispose of it.

9 - Replacing Faulty Components

Warning: It is important that before you start work on any equipment, you read the "[Safety Rules](#)" on page 48 and the specific warnings in each procedure.

9.1 - Replacing a Faulty Remote Unit

1. Remove the faulty remote unit from the support as follows:

- a Disconnect the faulty remote unit from mains.



Warning: Hot Surface

The heat sink could reach dangerous temperatures. Do not touch! Contact with the heat sink surface may cause burns. Allow the surface to cool before servicing.

- b Disconnect all cables (if necessary, label cables before disconnection).
- c Remove the 2 x M8X16 hex screws and 2 x M8 lock washers from the lower bracket-mount holes. Set the mounting hardware aside for later re-installation.

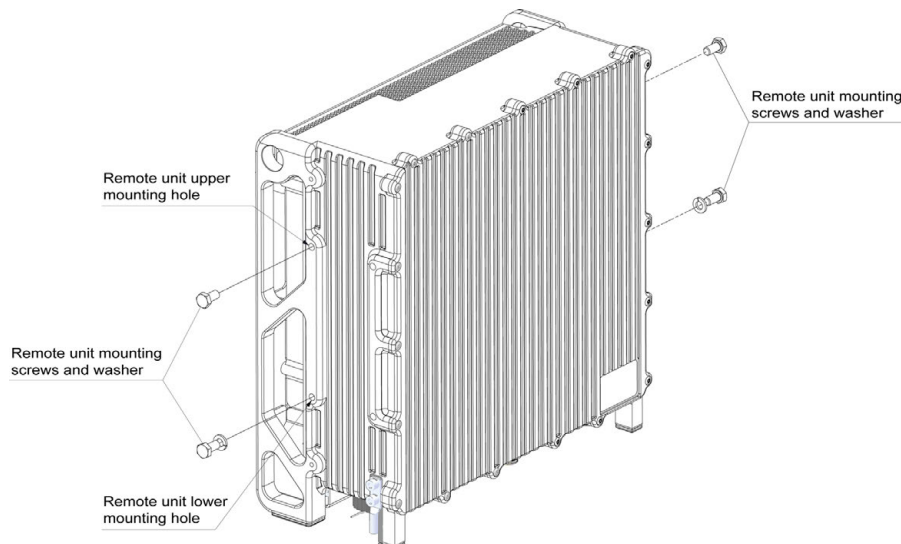

- d Carefully loosen the upper 2 x M8X16 hex screws just enough to remove the remote unit from the mounting bracket.
- e Lift the remote unit and remove it from the bracket.
- f Set the faulty remote unit aside.

2. Install the spare remote unit:

- a Mount the new remote unit, as described in the installation procedure. See "[Fastening Next Generation Remote Units to the Wall](#)" on page 12.
- b Reconnect the remote unit to the ground reference location.
- c Reconnect all the cables to the remote unit, except the power cord.
- d Connect the power cord.

3. Access the DAS supervision module web interface to discover the new component. See *JMA DAS Platform Remote Monitoring and Management User Guide*.

9 - Replacing Faulty Components

9.2 - Replacing a Faulty Fan Unit

Note: The fan unit must be replaced only when the *Fan Speed* alarm occurs.

Warning:

- It is important that before you start work on any equipment, you read the "[Safety Rules](#)" on page 48.
- Before you start work on the equipment, it shall be isolated from the power supply source.

Replacement instructions

▪ **Tools and equipment:**

- RD-TFAN-KIT, fan replacement kit for next generation remote units with forced-air cooling
- Crosshead screwdriver

▪ **Procedure:**

1. Remove the remote unit from the mounting bracket and place it on a stable surface:
 - a Disconnect the remote unit from mains.
 - b Allow the unit to cool down.



Warning: Hot Surface

The heat sink could reach dangerous temperatures. Do not touch! Contact with the heat sink surface may cause burns. Allow the surface to cool before servicing.

- c Disconnect all cables (if necessary, label cables before disconnection).
- d Remove the 2 x M8X16 hex screws and 2 x M8 lock washers from the lower bracket-mount holes. Set the mounting hardware aside for later re-installation.

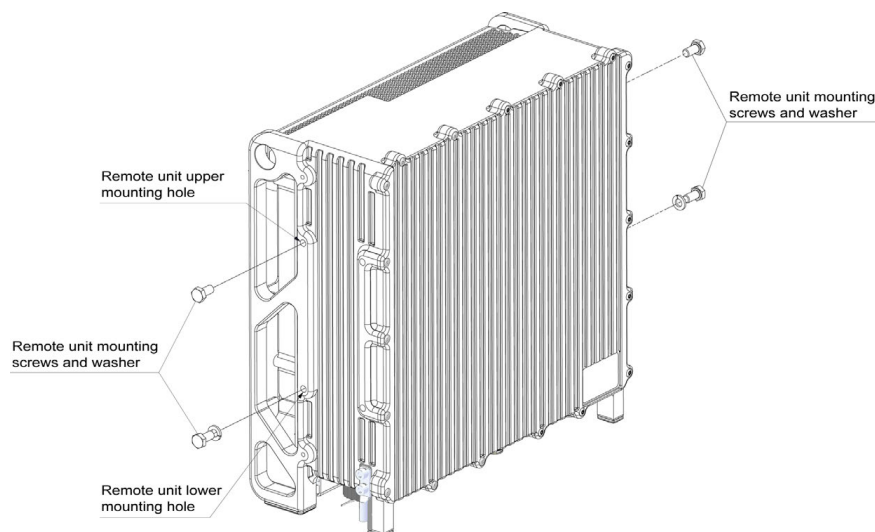

- e Carefully loosen the upper 2 x M8X16 hex screws just enough to remove the remote unit from the mounting bracket.

9 - Replacing Faulty Components

- f Lift the remote unit and remove it from the bracket.
- g Gently lay the remote unit on the front side on a stable surface.

2. Remove the faulty fan unit:

- a Insert the crosshead screwdriver into the fan unit fixing screws holes.



- b Loosen the two M3 captive screws that secure the fan unit to the remote unit case.
- c Lift the fan unit up to disconnect the connector for power supply and control of the fan unit, then remove the fan unit.

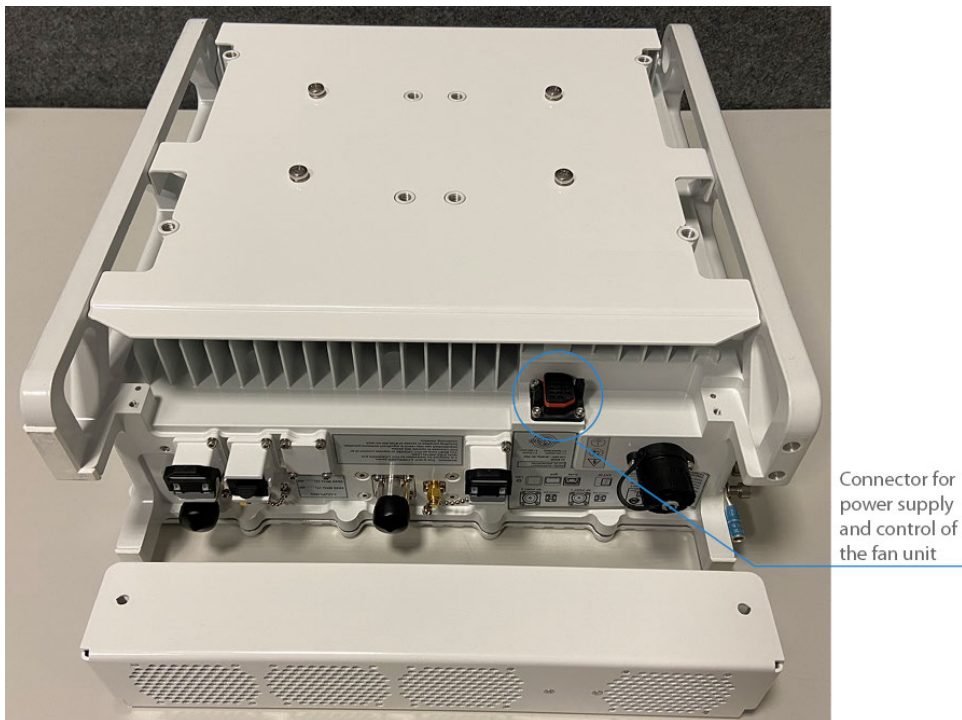

Connector for power supply and control of the fan unit

3. Install the new fan kit:

- a Position the fan replacement kit making sure to properly align the connectors for power supply and control of the fan unit.

9 - Replacing Faulty Components

- b Secure the fan kit to the remote unit tightening the M3 captive screws available in the RD-TFAN-KIT.



4. Place the remote unit back onto the mounting bracket and secure, following the procedure described in ["Fastening Next Generation Remote Units to the Wall" on page 12](#).
5. Reconnect the remote unit to the ground reference location.
6. Reconnect all the cables to the remote unit, except the power cord.
7. Connect the power cord.
8. Access the DAS supervision module web interface and check that the *Fan Speed* alarm is no longer active for the remote unit. Refer to the *JMA DAS Platform Remote Monitoring and Management User Guide*.

10 - Compliance with the Technical Regulatory Standards

10.1 - Compliance with the EU and UK Regulatory Requirements

10.1.1 - EU Directive 2014/53/EU – RED (Radio Equipment Directive) and Radio Equipment Regulations 2017 (S.I. 2017/1206)



The products described in this technical handbook comply with EU directive 2014/53/EU on the harmonization of the laws of the Member States and Radio Equipment Regulations 2017, relating to the making available on the market of radio equipment, when properly installed, maintained, and used for their intended purpose: improving coverage of mobile communication networks.

A signed copy of the Declaration Of Conformity is available upon request.

For further information, contact the JMA After Sales department at www.jmawireless.com

Teko Telecom S.r.l. a socio unico

Via Meucci 24/a

40024 Castel San Pietro Terme (Bologna) – Italy

Radio Equipment Operating Frequency Bands

Operating bands	Downlink (DL) and Uplink (UL) Operating Frequencies (MHz)
3500TDD	3400-3800 (DL/UL)

Maximum Radio-frequency Power Transmitted in the Frequency Bands

Operating Band	3500TDD
Maximum downlink output power (dBm)	46
Maximum downlink gain (dB)	48
Maximum uplink output power (dBm)	6
Maximum uplink gain (dB)	47

10 - Compliance with the Technical Regulatory Standards

10.1.1.1 - Note Relevant to Product Utilization within the European Union (EU)

Equipment is only for professional use; only adequately trained personnel can operate the equipment. Installation and commissioning must be authorized and carried out by the Mobile Network Operator (MNO) or its authorized representative. The use of the equipment must be in accordance with the MNO.

Depending on the country of utilization, the installation and use of the equipment described in this manual may be subject to restrictions. Users are responsible for verifying compliance with the national provisions or authorization required.

For further information refer to: <https://efis.cept.org/>

	AT	BE	BG	CH	CY	CZ	DE
	DK	EE	EL	ES	FI	FR	HR
	HU	IE	IT	IS	LI	LT	LU
	LV	MT	NL	NO	PL	PT	RO
	SE	SI	SK	TR	UK(NI)		

10.1.1.2 - Compliance with the Maximum Permissible Exposure (MPE) Limits (EN 50385)

Examples of Minimum Separation Distance Calculation, Based on the EN 50385

The following table summarizes the results of the calculations carried out assuming:

- Zero losses between the output connector of JMA equipment and the input connector of the antenna
- Maximum gain estimated for outdoor Antenna $G_i = 19\text{dBi}$ (for each band)
- Maximum gain estimated for indoor Antenna $G_i = 7\text{dBi}$ (for each band)
- No co-location or operation in conjunction with any other antenna or transmitter.

Note: The following table is **not** meant to represent the actual compliance distance from a particular JMA Distributed Antenna System, being antennas, cables, and other RF components not provided with JMA equipment. The actual compliance distance from a particular equipment can be calculated in the final installation phase only - when antenna, cables and other RF components specifications are available.

Equipment	Type	Maximum Output Power (dBm)	Minimum separation distance between a person and the antenna in order to comply with MPE limits [m]			
			Indoor Installation		Outdoor Installation	
			E=6 [V/m]	E=20 [V/m]	E=6 [V/m]	E=20 [V/m]
Next Generation remote unit	Very-very-high-power (40W) single band MIMO Next Generation remote units	49	17.9	5.7	71.1	22.5
	Dual-band, upgradable 10/20/40W, MIMO, Next Generation, Software Defined Remote Units (SDRU)	52	25.2	8.0	100.6	31.8

10 - Compliance with the Technical Regulatory Standards

10.1.2 - EU Directive 2015/863/EU – RoHS (Restriction of the Use of certain Hazardous Substances)

This product complies with EU Directive 2015/863/EU on Restriction of the use of certain Hazardous Substances in electrical and electronic equipment (also known as “RoHS 3”). The product does not contain the substances listed in the Directive in concentrations higher than the maximum admitted values.



The Environmental Friendly Use Period (EFUP) for all enclosed products and their parts are per the symbol shown here, unless otherwise marked. Certain parts may have a different EFUP (for example, battery modules) and so are marked to reflect such. The Environmental Friendly Use Period is valid only when the product is operated under the conditions defined in the product manual.

10.1.3 - EU Directive 2012/19/EU – WEEE (Waste Electrical and Electronic Equipment)

This product complies with the EU directive 2012/19/EU – WEEE (Waste Electrical and Electronic Equipment)



The symbol of the crossed container marked on the equipment shows that the product, at the end of its useful life, must be collected separately from other refuse. Therefore the user must deliver the equipment that has reached the end of its life to the special differentiated electronic and electrotechnical refuse collection centers for subsequent dispatch of the discarded equipment for recycling, treatment, and environmentally compatible disposal, thus contributing in preventing possible negative effects on the environment and on health and favoring the recycling of the materials from which the equipment is made.

Illicit disposal of the product by the user will lead to the application of the penalties provided for by the national legislations of the various Member States on receipt of directive 2012/19/EU.

For further information, contact the JMA After Sales department: www.jmawireless.com

10.1.4 - Packaging and Packaging Waste Directive 94/62/EC and Subsequent Amendments

The packaging of the product complies with the Directive 94/62/EC and subsequent amendments, concerning packaging and packaging waste. Environmentally harmful materials are not used for packaging.

Packaging is made from materials that can easily be recycled after use. Depending on the means of transportation, the equipment is packed in a cardboard or wooden box, protected with expanded polystyrene or barrier bags.

The packaging materials are marked according to ISO 11 469.

10 - Compliance with the Technical Regulatory Standards

Do not throw packaging materials into unsorted waste. Instead, separate them according to local regulations of waste disposal options.

10.2 - Compliance with FCC Rules and Regulations



All JMA equipment complies with the applicable rules described in Title 47 CFR (Code of Federal Regulations), Part 15.

For further information regarding Supplier's Declaration of Conformity, please contact the representative of responsible party:

Yatin Buch, ybuch@jmawireless.com, Liverpool, New York 13088 USA, Mobile: +1 315-382-3341

This device complies with part 15 of the FCC Rules. Operation is subject to the following two conditions: (1) This device may not cause harmful interference, and (2) this device must accept any interference received, including interference that may cause undesired operation.

This equipment has been tested and found to comply with the limits for a Class B digital device, pursuant to part 15 of the FCC Rules. These limits are designed to provide reasonable protection against harmful interference in a residential installation. This equipment generates, uses and can radiate radio frequency energy and, if not installed and used in accordance with the instructions, may cause harmful interference to radio communications. However, there is no guarantee that interference will not occur in a particular installation. If this equipment does cause harmful interference to radio or television reception, which can be determined by turning the equipment off and on, the user is encouraged to try to correct the interference by one or more of the following measures:

- Reorient or relocate the receiving antenna.
- Increase the separation between the equipment and receiver.
- Connect the equipment into an outlet on a circuit different from that to which the receiver is connected.
- Consult the dealer or an experienced radio/TV technician for help.

Changes or modifications not expressly approved by the party responsible for compliance could void the user's authority to operate the equipment.

The antenna(s) used for this transmitter must be installed to provide a separation distance from all persons as follows, assuming no co-location or operating in conjunction with any other antenna or transmitter:

- at least 150cm for single-band very-very-high-power next generation remote units family in MIMO application (with 5.5dB of maximum antenna gain for operating bands higher than 1.5GHz).
- at least 200cm for dual-band very-very-high-power next generation remote units family in MIMO application (with 5dB of maximum antenna gain for operating bands higher than 1.5GHz).

10 - Compliance with the Technical Regulatory Standards

- at least 150cm for dual-band high-power next generation remote units family in MIMO application (with 11.5dB of maximum antenna gain for operating bands higher than 1.5GHz).

Because the external antenna is not provided with the equipment, specifications of antennas, cables, RF components, and similar equipment will be provided in the final installation phase.

10.2.1 - Radio Equipment Operating Frequency Bands: Commercial Bands

Operating bands	Downlink (DL) and Uplink (UL) Operating Frequencies (MHz)
3.45GHz C-band	DL/UL 3450–3550MHz
C-band	DL/UL 3700–3980MHz

Warning for Commercial Bands

WARNING. This is NOT a CONSUMER device.
It is designed for installation by FCC LICENSEES and QUALIFIED INSTALLERS.
You **MUST** have an FCC LICENSE or express consent of an FCC Licensee to operate this device.
Unauthorized use may result in significant forfeiture penalties, including penalties in excess of \$100,000 for each continuing violation.

11 - Attachments

11.1 - Getting Help: Technical Support Contact Information

- JMA International
+1 315 431-7100
+1 888 201-6073
customerservice@jmawireless.com
- JMA United States
Toll Free +1 888 201-6073, Outside US +1 315-431-7100
techsupport@jmawireless.com
- JMA Italy - BTC
+39 051 6946811
VAS-techsupport@jmawireless.com

11 - Attachments

11.2 - Safety Rules

Introduction

The equipment described in this technical handbook has been designed and tested in conformity of international safety standards IEC60950/EN60950 and/or IEC62368/EN62368. This equipment must be used under the responsibility of specialized personnel only.

In accordance with IEC60950/EN60950 and/or IEC62368/EN62368, adjustment, maintenance and repair of the exposed equipment shall be carried out only by qualified personnel who are aware of the hazards involved. The minimum qualifications are established in the standard.

Final installation of the systems must fulfill the EMF emission levels, as required by regulations in force.

Safety Precautions

It is essential that both operation personnel and services personnel follow generally accepted safety procedures (IEC60950/EN60950 and/or IEC62368/EN62368) - in addition to the safety precautions specified in this technical handbook - for the correct and safe use of the equipment.

Specific warnings and caution statements, where applicable, can be found throughout this technical handbook.

Warning and caution statements and/or symbols are marked on the equipment where necessary.

Caution: used to indicate the correct operation and maintenance, in order to prevent damage or destruction of equipment or other property.

Warning of danger: used to indicate the potential hazard that requires correct procedures or practices in order to avoid personal injury.

As far as the equipment safety devices are concerned:

- Periodic functional check shall be carried out on protective devices.
- Functional check shall be carried out on protective devices, when they have operated under fault conditions.
- Safety devices shall not be altered or disconnected except for replacement.
- Safety circuits shall not be modified.

Impaired Safety Protection

Whenever it is likely that safe operation is impaired, the equipment must be inoperative and secured against unintended operation.

The appropriate servicing staff authority must be informed.

For instance, the safety is likely to be impaired if the equipment fails to perform the prescribed measurements or shows visible damages.

11 - Attachments

Electrostatic Sensitive Devices

Electrostatic sensitive devices (for instance, all ICs and many other semiconductor devices) require correct protection to reduce the risk of personal injury.

Careless handling, during repair, may imply life danger.

When repairing such devices, make sure that you are connected with the same potential as the ground of the equipment by means of the right devices, for example, a GIRDLE (a wrist wrap with resistance) and a WINDING CORD to be connected to the girdle and to the relevant socket placed on the equipment.

You must also keep components and tools at this potential.

Electrolytic Capacitors

Non-solid electrolytic capacitors must not contain chemicals, which may be regarded as hazardous if incorrectly handled. Caution is necessary if the outer case is fractured.

Electric Shock

In case of electric shock, do not touch the person before breaking the circuit by means of the power supply switch. If it is not possible to break the circuit power supply, try to rescue the person by means of some insulating materials: for example, a wooden stick, a nylon cord, or a suitable service made of plastic.

NEVER TOUCH ELECTROCUTED PEOPLE WITH YOUR HAND AS LONG AS THEIR BODIES ARE SUBJECTED TO VOLTAGE. IF YOU DO, YOU TOO WOULD BE ELECTROCUTED.

Call the doctor and then immediately perform the artificial respiration as described here below:



Lay the patient on their back with their arms parallel to their body; if the patient lies on an inclined plane, please make sure that their stomach is slightly lower than their breast. Open the patient's mouth and check for the presence of foreign bodies.

Kneel down near the patient at the same level as their head, then put one of your hands under their head and the other one under their neck. Lift the patient's neck and let their head fall backwards as far as possible.

Shift your hand from the patient's neck to their chin; put your thumb between their chin and their mouth, put your forefinger along their jawbone, and keep your other fingers tight. Start the self-oxygenation by deep breathing in standing open-mouthed. With your thumb between the patient's chin and their mouth, keep the patient's lips closed and blow into their nasal cavities.

11 - Attachments

During these operations see if the patient's breast rises. If not, their nose may be obstructed; in this case, by levering on their chin with your hand, open the patient's mouth, put your lips on and blow into their oral cavity. Look at the patient's breast and see if it rises. One can also use this second method if the patient's nose is not obstructed, as long as their nose be occluded by squeezing their nostrils with your hand after shifting it from their head. The patient's head must be kept bent backwards as far as possible.

Start with 10 fast and deep expirations, then go on at the rhythm of 12 to 15 expirations per minute. Continue as long as the patient has recovered consciousness, or until a doctor has ascertained their death.

Burns

For burns:

- Do not try to take off clothes from the burnt parts.
- Pour some cold water on body burnt areas and ask immediately for a doctor.
- Do not apply ointments or oily tinctures.

11.2.1 - Annex

When the equipment or the modules are equipped with the labels shown here below, it is essential to observe the warnings contained:

- Live Voltage Point

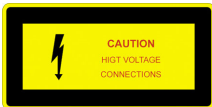

- Protective Earthing Terminal

Connect the equipment to the nearest ground reference location, before connecting power supply.

The protective earthing terminal can be identified by this symbol: 

- Caution! Shock hazard! Disconnect all power sources

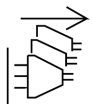

- Caution! High touch current. Connect to earth before connecting to supply.



11 - Attachments

▪ Class 1 Laser Product



Products which are of Class 1 invisible radiation, as defined in the IEC/EN 60825-1:2014 "Safety of laser products - Part 1: Equipment classification, requirements and user's guide".

The product has been classified according to the IEC/EN 60825-1:2014 standard with:

- maximum output of laser radiation: 15mW
- type of emission: continuous
- optical emitted wavelength: 1310nm (second window), 1490-1570 nm (third window)

Note: Even if the product is of CLASS 1, please observe the following safety procedures, prescribed in the cited norm:

- do not observe directly the laser beam,
- do not use observation optics (lens, microscopes, telescopes, etc.),
- do not expose eyes directly.

▪ Hot Surface



Warning: Do not touch the surface. Contact with the surface may cause burns. Allow the surface to cool before servicing.

▪ Devices sensitive to the electrostatics



Caution: Observe due precautions in handling devices which are sensitive to the electrostatics.

▪ Non-solid electrolytic capacitors may contain chemicals to be regarded as hazardous, if incorrectly handled.



Warning: Maximum caution is required if the outer case is fractured.

11.3 - Warnings and Caution Statements

This section supplements the installation guide safety rules, providing a list of the warnings and caution statements that can be found throughout this installation guide.

Installation

- A correct system installation and setting procedure requires a good knowledge of and experience in installing telecommunication equipment.
- To ensure proper installation and configuration, these activities should be performed by skilled and experienced personnel only.
- Before you install the equipment, carefully read the safety rules attached to this document. See ["Safety Rules" on page 48](#).
- Before you start work on any equipment, make sure it is isolated from the power supply source.
- If not approved by JMA, repainting any components of the DAS voids the warranty.
- The equipment is intended to be installed in a Restricted Access Location (RAL) where the equipotential bonding has been applied. RAL is defined as a location for equipment where both of the following conditions apply:
 - Access can be gained only by SERVICE PERSONS or by USERS who have been instructed about the reasons for the restrictions applied to the location and about any precautions that shall be taken.
 - Access is gained using a TOOL or lock and key, or other means of security, and is controlled by the authority responsible for the location.
- In Denmark, Finland, Norway and Sweden, the equipment intended for connection to other equipment, or a network shall have a marking stating that the equipment must be connected to an earthed mains socket outlet.

In Finland: *"Laite on liitettävä suojakoskettimilla varustettuun pistorasiaan"*.

In Norway: *"Apparatet må tilkoples jordet stikkontakt"*.

In Sweden: *"Apparaten skall anslutas till jordat uttag"*.

In Denmark: *"Apparatets stikprop skal tilsluttes en stikkontakt med jord, som giver forbindelse til stikproppens jord"*.

Installing Remote Units

- Before you install the equipment, carefully read the ["Safety Rules" on page 48](#), the ["Installation Site Requirements" on page 10](#), and the ["Precaution and Warning Statements" on page 10](#).
- Verify that the remote unit is not connected to the power supply source and that the switch upstream of the unit is open.
- Fasteners are not provided with the remote unit. Make sure that the mounting hardware is suitable for the support (recommended hardware: 4xM8 hex screws, property class 8.8, minimum length 25mm).

11 - Attachments

- Verify that the mounting surface and fasteners can support four times the weight of the equipment.

Equipment Commercial Code	Weight
RD35BWW2AT, RD35BWW2DT, RD35BWX2AT, RD35BWX2DT RD35TWW2AT, RD35TWW2DT, RD35TWX2AT, RD35TWX2DT RD35IWX2AT, RD35IWX2DT	18.5kg (41lb)
RD35B35TWX2AT, RD35B35TWX2DT	19.7kg (43lb)
RD35B35TWH2AT, RD35B35TWH2DT	18.2kg (40lb)

- Verify there is adequate manpower to handle the remote unit.
- After installation, verify adequate mounting of the remote unit. See "[Verification of Remote Unit Mounting](#)" on page 18.

Connections

- Ethernet or coaxial ports that use a shielded cable must be shielded and grounded at both ends.
- Bare conductors must be coated with antioxidant before crimp connections are made.

Optical Connections

Warning: When handling fiber optic devices, observe the following precautions:

- Never stare directly into fiber optic connectors and fibers. Invisible emitted laser beams can damage your eyes.
- Before you inspect and clean optical ports and connectors, always turn off the laser source.
- Never inspect a fiber while looking into it or connecting it to a fiber scope while the laser is on. Before inspection, always turn off the laser source.

Caution:

- Fiber optic devices are sensitive to static electricity. When handling static-sensitive devices, observe due precautions in handling them to prevent damage from electrostatic discharge.
- Always cover optical connectors, adapters, and optical ports with caps to prevent dust from accumulating on the interface. Remove fiber optic protective caps prior to making connections.
- Before mating fiber optic connectors, inspect and clean the connectors and optical ports to ensure optimized performance.
- Optical connections must be made with care to avoid damaging the optical fiber or connectors.
- Do not bend fiber optic cable with a tight radius of curvature; the cable might be damaged and losses within the fiber might occur.

Connecting AC and DC Power

- Before you start work on any equipment, make sure it is isolated from the power supply source.
- Make sure that the power supply source provides the nominal voltage prescribed.

11 - Attachments

- Before you make electrical connections, connect each remote unit equipped in the system to the ground reference location nearest each unit. The ground bolt is located on the side of the remote unit and can be identified by the ground symbol.
- Equipment shall be connected to an earthed socket-outlet. Earthing connection of the socket-outlet requires verification by a skilled person.

Connecting AC Power

- Since the plug on the power supply cord is intended to serve as the disconnect device, the socket-outlet shall be installed near the equipment and shall be easily accessible.
- The equipment can be connected to an IT power distribution system.

AC Power Supply Cord Requirements

- If it is necessary to fit an AC power supply plug to a power cable, you must observe the standard wire coloring in the country of installation.
You must also ensure that the protective earth wire would be the last to break if the cable is subject to excessive strain.
- The detachable AC power supply cord set shall be no lighter than light PVC sheathed flexible cord (H03VV-F) for indoor installation and rubber (H07RN-F) or PVC (SJTW, for the United States and Canada only) for outdoor installation, according to IEC60227, UL 817 for the United States, and CSA C22.2 No.21 for Canada.
- The detachable AC power supply cord set shall comply with the following requirements:
 - nominal voltage 240Vac
 - maximum operating temperature $\geq 60^{\circ}\text{C}$ (140°F)
- For US/Canada market:
 - Minimum cord length is 1.5m.
 - If used in ITE Rooms, power supply cords must be no longer than 4.5m.
 - Flexible power supply cords must be compatible with Article 400 of the NEC and Tables 11 and 12 of the CEC.
 - Power supply cords for outdoor equipment must be suitable outdoor use type as required by Section 400.4 of the NEC and Rule 4-012 of the CEC, that is, marked water resistant, outdoor, W or W-A.
 - Power supply cords must have attachment plugs rated not less than 125 percent of the rated current of the equipment.

Connecting DC Power

- The Vdc input connector is the means to disconnect the equipment from DC mains supply. Remove it to disconnect the equipment from power supply source before operation.
- It is necessary to provide an external protective device from overcurrent (50A, 250V). The protective device should be compliant with the standards of the country of installation.
- The equipment is intended and designed to be connected to a DC power source with a maximum transient voltage up to 1.5kV.

11 - Attachments

DC Power Supply Cord Requirements

- The color of the wires inside the power cord should be compliant with the standard wire coloring in the country of installation.
- The detachable DC power supply cord set must meet the requirements for indoor or outdoor use, in accordance with the standards of the country of installation.
- The detachable DC power supply cord set shall comply with the following requirements:
 - nominal voltage 72Vdc
 - maximum operating temperature $\geq 75^{\circ}\text{C}$ (167°F)
- For US/Canada market:
 - Minimum cord length is 1.5m, with certain constructions (such as external power supplies) allowed to consider both input and output cord lengths into the requirement.
 - Power supply cords must be no longer than 4.5m, if used in ITE Rooms.
 - Flexible power supply cords must be compatible with Article 400 of the NEC and Tables 11 and 12 of the CEC.
 - Power supply cords for outdoor equipment must be suitable outdoor use type as required by Section 400.4 of the NEC and Rule 4-012 of the CEC, that is, marked water resistant, outdoor, W or W-A.
 - Power supply cords must have attachment plugs rated not less than 125 percent of the rated current of the equipment.
- **Replacement of Faulty Components**
 - It is important that before you start work on any equipment, you read the "[Safety Rules](#)" on page 48.
 -  **Warning: Hot Surface**
Warning: Do not touch the surface. Contact with the surface may cause burns. Allow the surface to cool before servicing.

11.4 - Règles de Sécurité

Introduction

L'équipement décrit dans ce manuel technique a été conçu et examiné dans la conformité des normes de sécurité internationales IEC60950/EN60950 et/ou IEC62368/EN62368; l'équipement doit être utilisé sous la supervision du personnel spécialisé seulement.

Selon IEC60950/EN60950 et/ou IEC62368/EN62368, l'ajustement, le réglage et la réparation de l'équipement exposé doivent être effectués seulement par le personnel qualifié, qui sont conscients des risques impliqués. Les qualifications minimum sont établies dans la norme.

L'installation finale des systèmes doit satisfaire les niveaux d'émission d'EMF, comme en a été demandé par les règlements en vigueur.

Consignes de sécurité

Pour une utilisation correcte et sûre du dispositif il est très importante que soit le personnel opérante soit le personnel de service suivent les procédures de surété acceptées (IEC60950 / EN60950 et/ou IEC62368/EN62368) en outre aux mesures de surété indiqués dans le présente manuel technique.

Admonitions spécifiques et avertissements de prudence, si applicables, se trouvent dans ce manuel.

Précaution, Prudence: on l'utilise pour indiquer le fonctionnement et l'entretien correcte afin d'éviter d'endommager ou détruire le dispositif ou autre propriété.

Mises en garde, Admonitions de danger: utilisé pour indiquer une risque potentiel qui demande correctes procédures ou pratiques pour éviter dommages à la personne.

Sur les points nécessaires on a indiqué les symboles qui tirent l'oeil et avertissements de précaution.

En ce qui concerne les dispositifs de sécurité de l'équipement s'il vous plait rappelez-vous cela:

- des contrôles fonctionnels périodiques doivent être effectués sur des dispositifs de protection;
- des contrôles fonctionnels doivent être effectués sur des dispositifs de protection, quand ils ont fonctionné dans des conditions de panne;
- les dispositifs de sécurité ne doivent pas être changés ou déconnectés sauf pour le remplacer;
- le circuit de sécurité ne doit pas être modifié.

Réduite protection de sureté

Dans les cas où le fonctionnement de sureté est probable que a faibli, le dispositif doit être inopérant et le fonctionnement involontaire doit être évité.

On devra informer de ca la direction du personnel de servise du dispositif en objet.

Par exemple, la sureté peut se dire faible dans le cas où les performances du dispositif ne sont pas celles prévues ou bien il présente dommages visibles.

Dispositives sensibles électrostatiques

En cas de dispositives sensibles électrostatiques (par ex. toutes circuits intégrés et plusieurs autres semiconducteurs appartient à ce classe) il est importante d'utiliser la protection apte pour réduires les risques de dommages personnels.

Manoeuvres impropres ou négligents pendant la réparation peuvent comporter un danger mortale.

Pendant la réparation, il faut s'assurer d'être branché avec le meme potentiel de la mise à sol du dispositif par les dispositives corrects, par ex. une GAINÉ (protection du poignet avec résistance) et un CABLE DE BOBINAGE, à brancher à la gaine et à la prise relative qui se trouve dans le dispositif.

Il faut aussi garder les composants et les outils à ce potentiel.

Condensateurs électrolitiques

Les condensateurs électroitiques non solides peuvent contenir éléments chimiques qui peuvent etre considerés dangereux si manipulés de facon non correcte.

Dans le cas où l'enveloppe extérieur est cassé il est nécessaire d'être prudent.

Fulguration

En cas de fulguration éviter de toucher la personne avant d'avoir coupé le circuit par l'interrupteur de ligne; si ca n'est pas possible, le dégager en employant des matériax isolants: bâtons de bois, corde de nylon, objets de plasique.

NE PAS TOUCHER LA PERSONNE FOUROYÉE JUSQ'À SON CORP EST SOUS-TENSION: ON PEUT RESTER FOUROYÉ.

Démander l'intervention d'un medecin donc pratiquer promptement la respiration artificielle comme indiqué en suite:



Mettre le blessé sur le dos avec bras parallele au corps; si le blessé est étendu sur un plan incliné, s'assurer que son estomac est légèrement plus en bas que sa poitrine: Ouvrir la bouche du blessé et controller qu'il n'y a pas de corps étrangers.

S'agenouiller près du blessé au niveau de sa tete, mettre une main sous la tete et une sous le cou. Soulever le cou du blessé et en laisser retomber la tete le plus possible à l'arriere.

Déplacer la main du cou au menton du blessé; placer votre pouce entre le menton et la bouche, l'index le long de l'os machoire, tenir les autre doigts serré. Pendant ces opérations commencer l'auto-oxigenation parmi profondes inspirations à bouche ouverte. Avec votre pouce entre menton et bouche du blessé lui tenir les lèvres serrés et souffler dans la cavité nasale.

11 - Attachments

Pendant ces opérations contrôler si la poitrine du blessé se soulève. En cas contraire il est possible que le nez est obstrué; alors en faisant pression sur le menton avec la main, ouvrir le plus possible la bouche du blessé, mettre ses lèvres autour et souffler dans la cavité orale. contrôler si la poitrine du blessé se soulève. On peut utiliser cette deuxième méthode au lieu de la première même quand le nez n'est pas obstrué, à condition que il est fermé en serrant les narines avec la main après l'avoir déplacé de la tête. La tête du blessé doit être tenue le plus possible inclinée à l'arrière.

Commencer avec dix rapide et profondes expirations, continuer donc au rythme de douze/quinze expiration par minute. Continuer jusqu'à quand le blessé reprend sa connaissance ou un médecin en constate le décès.

Brûlures

En ce qui concerne les brûlures:

- Ne pas essayer de détacher les vêtements des parties brûlées.
- Verser de l'eau et appeler d'urgence un médecin.
- Ne pas appliquer pommades ou teintures huileuses.

11.4.1 - Annexe

Alors que le dispositif ou les modules sont équipés avec les étiquettes indiquées ci-après, il est très important de suivre les indications indiquées:

- Partie sous tension

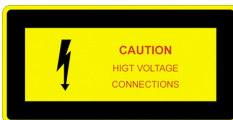

ATTENTION: connexions à haute tension

- Extrémité protectrice de mise au sol

Avant de brancher l'alimentation, branchez l'équipement à l'emplacement au sol le plus proche.

Le terminal de mise au sol peut être identifié par ce symbole: 

- Mise en garde! Danger de choc! Déconnecter toutes les sources d'énergie

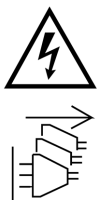

11 - Attachments

- *Mise en garde! Courant de contact élevé. Branchez à la terre avant de connecter à la source d'alimentation.*



- *Produit laser de Classe 1*



Les produits qui sont de classe 1 rayonnements invisibles sont définies dans la norme CEI / EN 60825-1:2014 "Sécurité des appareils à laser - Partie 1: Classification des matériels, prescriptions et guide de l'utilisateur".

Le produit a été classifié selon la norme IEC/EN 60825-1:2014 avec:

- *production maximale de rayonnement du laser: 15mW*
- *type d'émission : continu*
- *longueur d'onde optique émise: 1310nm (deuxième fenêtre), 1490-1570 nm (troisième fenêtre)*

Même si le produit est de classe 1, s'il vous plaît respecter les procédures de sécurité suivantes, prévues dans la norme citée:

- *ne pas observer directement le faisceau laser,*
- *ne pas utiliser l'optique d'observation (lentilles, microscopes, télescopes, etc),*
- *ne pas exposer directement les yeux.*

- *Surface chaude*



Attention: *Ne touchez pas la surface. Le contact avec la surface peut provoquer des brûlure. Laissez la surface refroidir avant tous les travaux d'entretien.*

- *Dispositives sensibles à l'électrostaticité*



ATTENTION: *observer les précautions qui s'imposent pendant la manipulation des dispositives sensibles à l'électrostaticité.*

- *Les condensateurs électrolytiques non solide peuvent contenir elements chimiques dangereux, dans le cas où ils ne sont as traité correctement.*



ATTENTION: *on demande la précaution maximale dans le cas où l'armoir exterieur presente des fractures.*

11.5 - Mises en Garde et Déclarations de Précaution

Ce document complète le manuel technique de l'équipement et les règles de sécurité, fournissant une liste des avertissements et de mises en garde qui peuvent être trouvées dans tout ce manuel technique.

Installation

Mise en garde

- L'installation correcte du système et la procédure de réglage exige une bonne connaissance et expérience dans l'installation d'équipements de télécommunication.
- Ces activités doivent être effectuées uniquement par du personnel qualifié.
- Avant d'installer l'équipement, lisez attentivement les règles de sécurité attachées au manuel technique d'équipement. Voir "[Règles de Sécurité](#)" on page 56.
- Avant de commencer à travailler sur l'équipement, il doit être isolé du réseau électrique.
- S'il n'est pas approuvé par JMA, repeindre les composants du DAS annulera la garantie.
- L'équipement est destiné à être installé dans un emplacement à accès restreint où une liaison équipotentielle de protection a été appliquée.

Le lieu d'accès restreint est un endroit pour les équipements où les deux conditions suivantes s'appliquent:

- l'accès peut seulement être acquis par des PERSONNES de SERVICE ou par les UTILISATEURS qui ont été instruits sur les raisons des restrictions appliquées à l'emplacement et sur toutes les précautions qui doivent être prises;
- l'accès se fait par l'utilisation d'un outil ou d'une clé, ou d'autres moyens de sécurité, et est contrôlé par l'autorité chargée de l'emplacement.

Installation des Unités à Distance

- Avant d'installer l'équipement, lisez attentivement les règles de sécurité attachées au manuel technique d'équipement. Voir "[Règles de Sécurité](#)" on page 56.
- Assurez-vous que les unités à distance ne sont pas connectées au réseau et que le commutateur ascendant de l'appareil est ouvert.
- Assurez-vous que les attaches utilisés pour le montage mural de l'unité à distance sont adaptés à la paroi (recommandées 4xM8 vis à tête hexagonale, classe de qualité 8.8, longueur minimale 25mm).
- Assurez-vous que la surface de montage est stable et capable de supporter quatre fois le poids de l'unité à distance. Voir "[Technical Specifications](#)" on page 1.

Équipement	Poid
RD35BWW2AT, RD35BWW2DT, RD35BWX2AT, RD35BWX2DT RD35TWW2AT, RD35TWW2DT, RD35TWX2AT, RD35TWX2DT RD35IWX2AT, RD35IWX2DT	18.5kg (41lb)
RD35B35TWX2AT, RD35B35TWX2DT	19.7kg (43lb)
RD35B35TWH2AT, RD35B35TWH2DT	18.2kg (40lb)

11 - Attachments

- Vérifiez qu'il y a de à de main d'œuvre appropriée pour manipuler l'unité à distance.
- Après l'installation mécanique, vérifiez le montage adéquat de l'unité à distance. Voir ["Verification of Remote Unit Mounting" on page 18.](#)

Connexions

- Les ports Ethernet / coaxiaux qui utilisent un câblé blindé doivent être blindés et mis à la terre aux deux extrémités.
- Les conducteurs nus doivent être recouverts d'antioxydant avant effectuer les connexions pincées.

Installation des Fibres Optiques et des Dispositifs aux Fibres Optiques

Respecter les procédures de sécurité suivantes:

- Ne pas observer directement le faisceau laser, ne pas utiliser l'optique d'observation (lentilles, microscopes, télescopes, etc), ne pas exposer directement les yeux.
- Protégez toujours les connecteurs optiques et les adaptateurs avec leur bouchon pour empêcher la poussière de joindre à la face d'extrémité. Retirez les capuchons de protection de la fibre optique juste avant de faire les connexions.
- Avant l'inspection de la fibre, arrêtez toujours la source laser. Alors que le laser est allumé, n'inspectez jamais une fibre en la regardant directement ou en la reliant à un fibroscope.

Alimentation d'Énergie

- Avant de faire les connexions électriques, l'équipement doit être isolé du réseau électrique.
- Assurez-vous que la source d'alimentation fournit la tension nominale prescrite.
- Avant d'effectuer les connexions électriques, connecter chaque unité à distante fourni dans le système à l'emplacement au sol le plus proche de chaque unité. Le boulon au sol est situé sur le côté de l'unité à distance et peut être identifié par le symbole de terre.
- L'équipement doit être connecté à une prise de courant reliée à la terre. Mise à la terre de la prise de courant doit être vérifiée par du personnel qualifié.

Alimentation en Courant Alterné (AC)

- Puisque la prise sur la corde d'alimentation d'énergie est prévue pour servir les dispositifs de débranchement, la prise de courant doit être installée près de l'équipement et doit être facilement accessible.
- L'équipement peut être installé dans un système de distribution IT.

Cordon d'Alimentation AC

- S'il est nécessaire de connecter une prise d'alimentation AC à le câble d'alimentation, l'utilisateur doit respecter les codes de couleur de fil standard dans le pays d'installation.

L'utilisateur doit également s'assurer que le fil de protection de terre soit le dernier à se rompre si le câble est soumis à une contrainte excessive.

11 - Attachments

- *L'ensemble de cordon d'alimentation détachable AC ne doit pas être plus léger que le cordon flexible engainé léger par PVC (H03VV-F) pour une installation à l'intérieur et en caoutchouc (H07RN-F) ou en PVC (SJTW, pour les États-Unis et le Canada uniquement) pour installation à l'extérieur, selon IEC60227, UL 817 pour les États-Unis et CSA C22.2 No.21 pour le Canada.*
- *L'ensemble du cordon d'alimentation détachable AC doit se conformer aux exigences suivantes:*
 - *tension nominale de 240Vac*
 - *température de fonctionnement maximale $\geq 60^{\circ}\text{C}$ (140°F)*
- *Pour les États-Unis et le Canada:*
 - *La longueur minimum du cordon est tenue d'être de 1,5 m.*
 - *Les cordons d'alimentation ne doivent pas dépasser 4,5 m de longueur, s'ils sont utilisés dans les salles d'équipement informatique (ITE).*
 - *Les cordons d'alimentation souples doivent être compatibles avec l'article 400 de la NEC, et les tableaux 11 et 12 de la CEC.*
 - *Les cordons d'alimentation doivent être adaptés à l'utilisation en plein air tel que requis par l'article 400.4 du NEC et par l'article 4-012 de la CEC, marquée résistant à l'eau, en plein air, W ou W-A.*
 - *Les cordes d'alimentation sont exigées d'avoir des prises d'attache notés au moins 125 pour cent du courant nominal de l'équipement.*

Alimentation en Courant Continu

- *Le connecteur d'entrée Vdc est le moyen de déconnecter l'équipement de l'alimentation électrique du courant continu (d.c.). Retirez-le pour débrancher l'équipement de la source d'alimentation avant l'opération.*
- *Il est nécessaire de prévoir un dispositif de protection externe contre la surintensité (50A, 250V). Le dispositif de protection doit être conforme aux normes du pays d'installation.*
- *L'équipement est destiné et conçu pour être connecté à une source d'alimentation DC avec une tension transitoire maximale jusqu'à 1,5kV.*
- **Cordon d'Alimentation DC**
 - *La couleur des fils à l'intérieur du cordon d'alimentation doit être conforme à la couleur de fil standard dans le pays d'installation.*
 - *L'ensemble du cordon d'alimentation amovible DC doit être agréé et en conformité avec les normes de sécurité en vigueur dans le pays d'installation, pour une utilisation en plein air ou en intérieur.*
 - *L'ensemble du cordon d'alimentation amovible DC doit satisfaire aux exigences suivantes:*
 - *tension nominale de 72Vdc*
 - *température de fonctionnement maximale $\geq 75^{\circ}\text{C}$ (167°F)*

11 - Attachments

▸ *Pour les États-Unis et le Canada:*

- *La longueur minimum du cordon est tenue d'être de 1,5 m, dans certaines constructions les longueurs du fils d'alimentations externes autorisées à l'entrée et à la sortie doivent être considérées dans l'exigence.*
- *Les cordons d'alimentation ne doivent pas dépasser 4,5 m de longueur, s'ils sont utilisés dans les salles d'équipement informatique (ITE Rooms)*
- *Les cordons d'alimentation souples doivent être compatibles avec l'article 400 de la NEC, et les tableaux 11 et 12 de la CEC.*
- *Les cordons d'alimentation doivent être adaptés à l'utilisation en plein air tel que requis par l'article 400.4 du NEC et par l'article 4-012 de la CEC, marquée résistant à l'eau, en plein air, W ou W-A.*
- *Les cordes d'alimentation sont exigées d'avoir des prises d'attachelements notés au moins 125 pour cent du courant nominal de l'équipement.*

▪ **Remplacement des Composants**

- *Avant de remplacer des composants, lisez attentivement les règles de sécurité attachées au manuel technique d'équipement. Voir "[Règles de Sécurité](#)" on page 56.*













Attention: Surface chaude

Attention: *Ne touchez pas la surface. Le contact avec la surface peut provoquer des brûlure. Laissez la surface refroidir avant tous les travaux d'entretien.*

11 - Attachments

11.6 - Symbols and Manufacture Labels Affixed to the Product

▪ Symbols

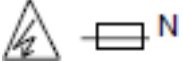
Symbol	Description
	Protective earthing terminal
	Direct Current (DC)
	Alternating Current (AC)
	Live Voltage Point
	Live Voltage Point
	Caution! Shock hazard! Disconnect all power sources
	Caution! High touch current. Connect to earth before connecting to supply.
	Class 1 Laser Product
	Hot surface. Do not touch the surface. Contact with the surface may cause burns. Allow the surface to cool before servicing.
	Devices sensitive to the electrostatics
	Non-solid electrolytic capacitors
	Caution. Neutral fusing.

11 - Attachments

▪ Manufacture Labels

All products are identified by a bar code label.



The following table provides a description of the bar code label fields.

Field	Description
A	Serial number of the module or equipment
A1	Encoded serial number of the module or equipment
B	Equipment acronym or manufacture part number
B1	Encoded equipment acronym or manufacture part number
C	CF (final test tracing out): when checked certifies that the item has been successfully tested in the Factory Final Test Dept.

Abbreviations

AGC

Automatic Gain Control

BS

Base Station

CPRI

Common Public Radio Interface

DAS

Distributed Antenna System

DE

Digital Electricity

DL

Downlink

DWDM

Dense Wavelength Division Multiplexing

eCPRI

evolved Common Public Radio Interface

EU

European Union

ITE

Information Technology Equipment

LAN

Local Area Network

LMT

Local Maintenance Terminal

LTE-TDD

Time-Division Long-Term Evolution

MU

Master Unit (modular headend)

Abbreviations

NEM

Network Element Manager

O-RAN

Open Radio Access Network

PDU

Power Distribution Unit

PIM

Passive Intermodulation

POI

Point of Interface

PSU

Power Supply Unit

RAL

Restricted Access Location

RF

Radio Frequency

RU

Remote Unit

SDRU

Software Defined Remote Unit

SFP

Small Form Factor Pluggable

TDFE

Digital Donor Front End

UI

User Interface

UK

United Kingdom

UL

Uplink

Abbreviations

UPS

Uninterruptible Power Supply

WAN

Wide Area Network

WDM

Wavelength Division Multiplexing