

JMA Weather Protection System™

WPS-4MT-12S-01, 1/2" Superflex 4MT Connector to Antenna or Device



Materials (all sold separately)



WPS-4MT-12S-01
boot



WPS-4F
2 port seals



UXP-4MT-12S-01
connector



TQ-78-F8
torque wrench

Step 1: Install WPS-4MT-12S-01 and port seal



Prior to cable prep, slide the WPS-4MT-12S-01 boot onto the 1/2" cable 8–12" from the end.



Prep the 1/2" cable and install the UXP-4MT-12S-01 connector. Refer to the connector installation instructions.



Install port seal, with text "This side away from nut" toward port.

Step 2: Connect and torque interface



Mate the male connector to the port.



Torque the connector to 8 lbf-ft using the TQ-78-F8 torque wrench.

WPS-4F compatible port specification

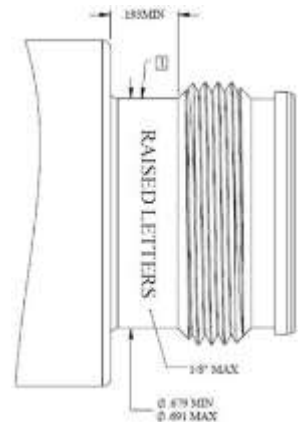

1 Surface to be free of flats, threads, or raised lettering whose characters are taller than 1/8".

Step 3: Install JMA WPS to seal interface



Slide the WPS-4MT-12S-01 over the port seal until ribs are no longer visible.



Properly installed WPS-4MT-12S-01.

NOTE: all ribs of the port seal are fully covered by the WPS.

JMA Weather Protection System™

WPS-4MT-12S-01, 1/2" Superflex 2MT Connector to Antenna or Device



Materials (all sold separately)



WPS-4MT-12S-01
boot



WPS-2F-12
2 port seals



UXP-2MT-12S-01
connector



TQ-916-F6
torque wrench

Step 1: Install WPS-4MT-12S-01 and port seal



Prior to cable prep, slide the WPS-4MT-12S-01 boot onto the 1/2" cable 8–12" from the end.



Prep the 1/2" cable and install the UXP-2MT-12S-01 connector. Refer to the connector installation instructions.



Install port seal, with text "This side away from nut" toward port.

Step 2: Connect and torque interface



Mate the male connector to the port.



Torque the connector to 6 lbf-ft using the TQ-916-F6 torque wrench.

WPS-2F compatible port specification

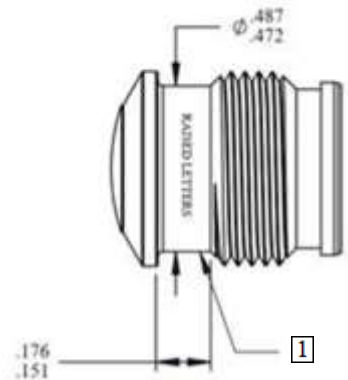

1 Surface to be free of flats, threads, or raised lettering whose characters are taller than 1/8".

Step 3: Install JMA WPS to seal interface



Slide the WPS-4MT-12S-01 over the port seal until ribs are no longer visible.



Properly installed WPS-4MT-12S-01.
NOTE: all ribs of the port seal are fully covered by the WPS.